

**BECKHOFF** New Automation Technology

The complete energy measurement chain:  
from the sensor to the cloud





# Simplified energy management, more availability

By completing the power measurement chain from the sensor to the cloud, PC-based control specialist Beckhoff simplifies energy management approaches and improves the availability of machines and production facilities. Permanent, system-integrated power measurement allows users to perform extensive inline analyses to detect deviations and take quick corrective action.

For example, a steady increase in a machine's power consumption may be an indicator of excessive wear on bearings, while declining power consumption may be a sign of quality problems that can be corrected early in time.

And a sudden drop in power usage means that immediate action in the production facility is needed. The bottom line: the more quickly you respond, the greater the chances of avoiding downtime.

Until now, continuous power monitoring involved a lot of effort. In many cases, external sensors must be installed at great cost, and sometimes this is possible only with special components such as motors equipped with temperature sensors.

With power measurement terminals from Beckhoff, however, this can be implemented using standard components, even as part of

retrofitting projects of existing machines and systems. And the effort involved is relatively low.

By measuring the power on an existing motor cable, for example, it is possible to detect asymmetrical currents directly within milliseconds and not just when the motor temperature is already on the rise. And to name another example, weak points in mechanical components can be identified based on vibrations due to the presence of increasing harmonic waves.

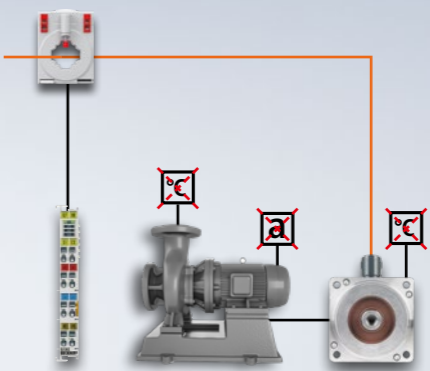

Power measurement terminal replaces external sensors

## The complete power measurement chain:

- reduces downtimes and prevents production losses
- can be implemented from the sensor to the cloud with Beckhoff components
- can be implemented with standard components
- simplifies power management in new machines and systems
- can be retrofitted quickly and easily to existing machines
- reduces time and cost requirements

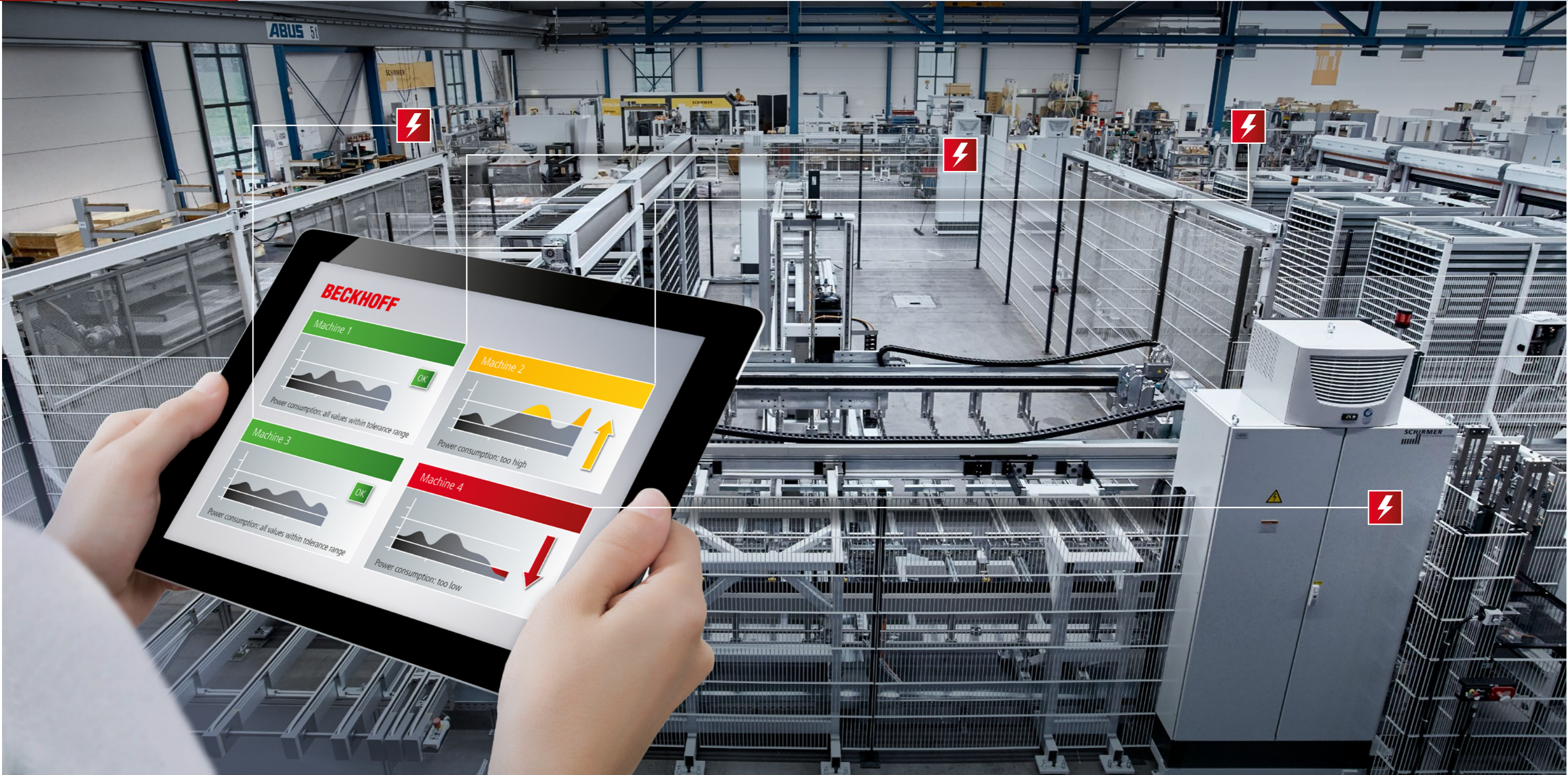



# From sensor to cloud: the Beckhoff measurement chain

As a system provider, Beckhoff completes with the SCT power sensor series the end-to-end chain from measuring the physical value to transmitting the data to the cloud. At the start of the measurement chain, the portfolio of current transformers covers all applications from 1 A to 5,000 A and from ring-type to split-core to 3-phase current transformers.

Stage 2 of the Beckhoff measurement chain consists of EtherCAT power measurement terminals that are highly scalable and therefore suitable for all applications ranging from maintenance to closed-loop control to power monitoring. The result: improved process control and

cost-effective power management. Other common sensors for variables such as force, pressure, temperature or rotational speed can be connected via other Beckhoff measurement I/O modules, which are available in various protection classes.

The communication is based exclusively on EtherCAT. As a powerful and established high-speed fieldbus for measurement technology, EtherCAT offers 100 Mbps user data rates for several hundred channels with 24 bit resolution and oversampling, synchronous scanning, cable redundancy, and timestamping with ns-resolution. Further performance leaps are possible with

EtherCAT G, which is based on the 1 Gbps transmission rates of standard Ethernet. EtherCAT G 10 even operates with 10 Gbps transmission rates. At the same time, openness remains at the core of the Beckhoff control architecture, because measurement data can also be captured with many other supported fieldbus systems such as PROFIBUS, PROFINET and Ethernet/IP, to name just a few.

The data can be transmitted to the cloud either via a local control IPC or the EK9160 IoT Coupler. By means of TwinCAT automation software, all machine functions from engineering, PLC, motion control, safety, visualization and

measurement technology to communication are governed by the local control PC-based control system. In addition, TwinCAT Power Monitoring provides special grid analysis functions. And with the IoT Coupler, all acquired data can be transferred safely and easily to the desired cloud environment via communication protocols such as OPC UA PubSub, AMQP or MQTT to support cloud-based engineering, centralized data analysis and easy integration with the storage services of various public cloud platforms, and other functions.

**Seamless Beckhoff measurement chain:**

- current transformers for power data capturing
- highly scalable EtherCAT energy measurement terminals
- the high-speed EtherCAT fieldbus
- comprehensive on-premise software solutions
- easy cloud connectivity with a wide range of analytics and storage functions

The measurement modules



The sensors



The measurement technology bus

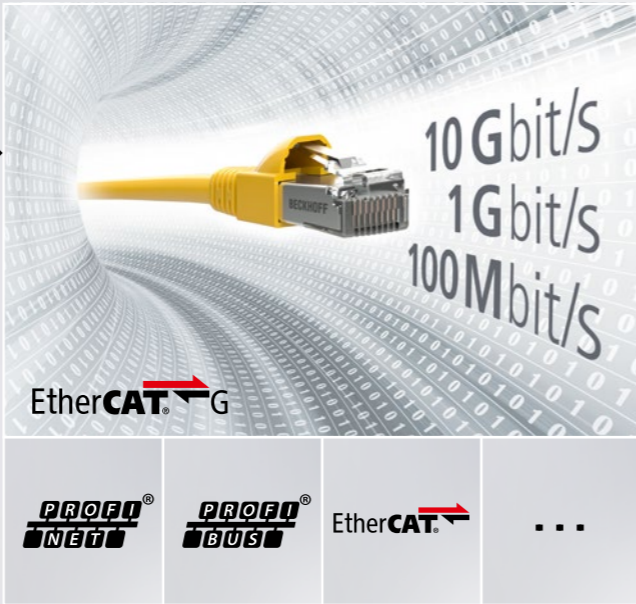

The EK9160 IoT Coupler



The measurement software used on premises

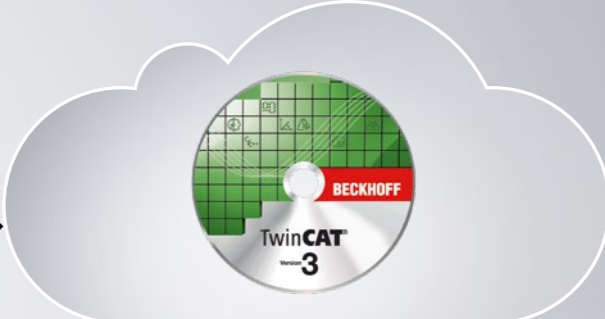

TwinCAT Cloud Engineering, private cloud or 3rd-party software in the cloud

# More transparency in energy management for machines and buildings

Machines and plants are dynamic systems that over the years grow or shrink and get modified, converted or otherwise adapted to new production requirements. The same applies to buildings and properties. Their infrastructure also changes as a result of additions and conversions, expansions and changes in usage. To achieve maximum transparency when the system architecture of machines or buildings has grown over time and become unwieldy, it is advisable to install a comprehensive energy and power measurement system with integrated terminals that reliably collect all relevant data and allows users to carry out cloud-based analysis according to their requirements.

To make the evaluation of current performance indicators as user-friendly as possible, Beckhoff has developed the so-called power quality factor (PQF). It allows users to assess the voltage quality for a machine or system based on a single number without first having to analyze frequency, voltage, THD/harmonics and symmetry individually.

For example, if a machine malfunction occurs and the PQF simultaneously drops to zero, it's safe to conclude that the fault does not lie in the machine itself, but in the power supply. This speeds up troubleshooting symptoms and consequences of a fault as well as correcting its causes. A declining PQF can also serve as an early-warning system.

And last but not least, the PQF makes it easier to clarify potential liability questions.

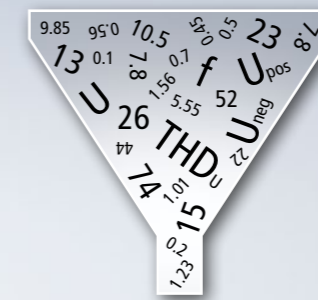

PQF

Power Quality Factor: a single value for simplified, faster diagnostics and error correction

## Increased transparency through:

- simplified power management in historically grown installations of machines, systems and buildings
- Power Quality Factor (PQF): a single number replaces complex analysis of multiple individual values
- simplified troubleshooting and faster clarification of liability questions
- PQF can serve as an early-warning system for predictive maintenance

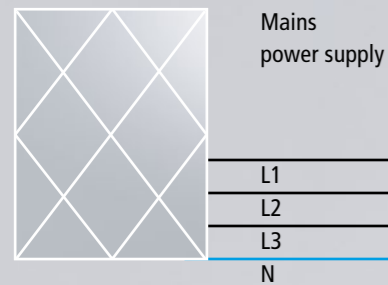

## Building energy management system

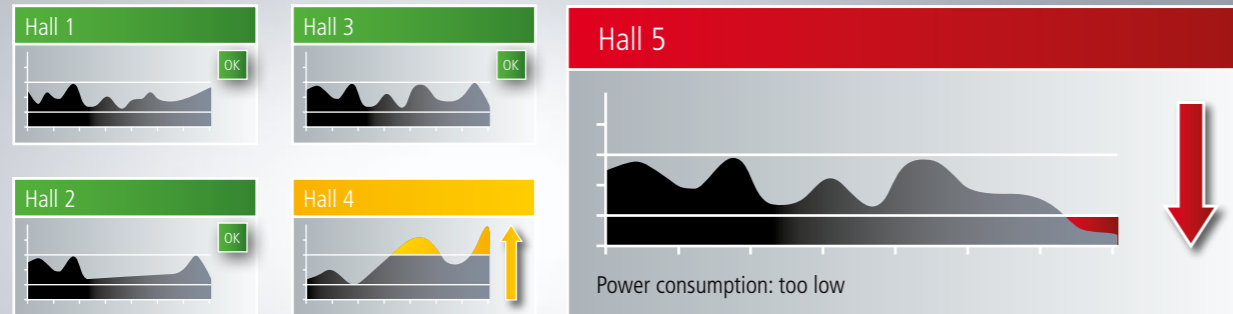

## Machine energy management system

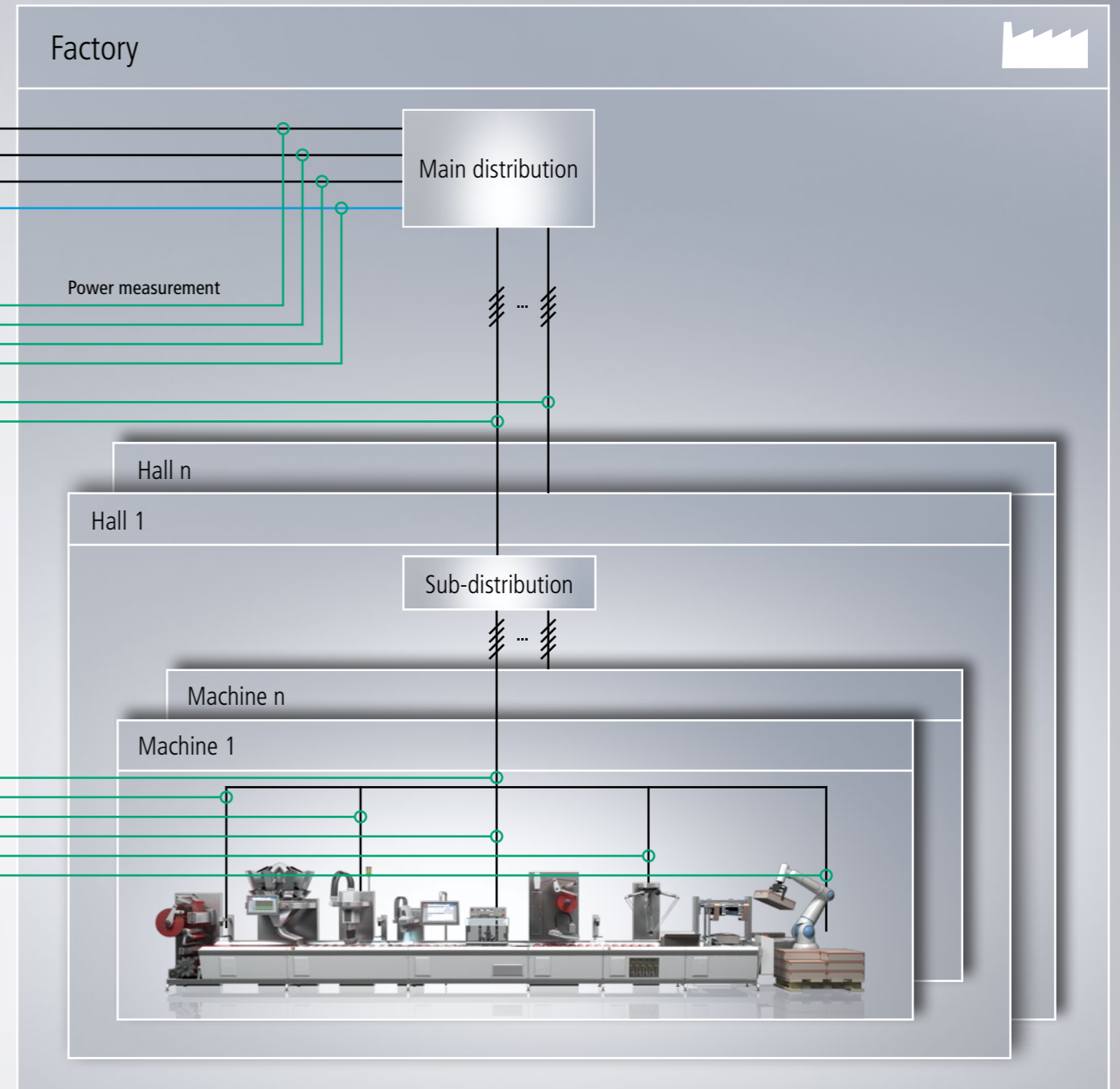
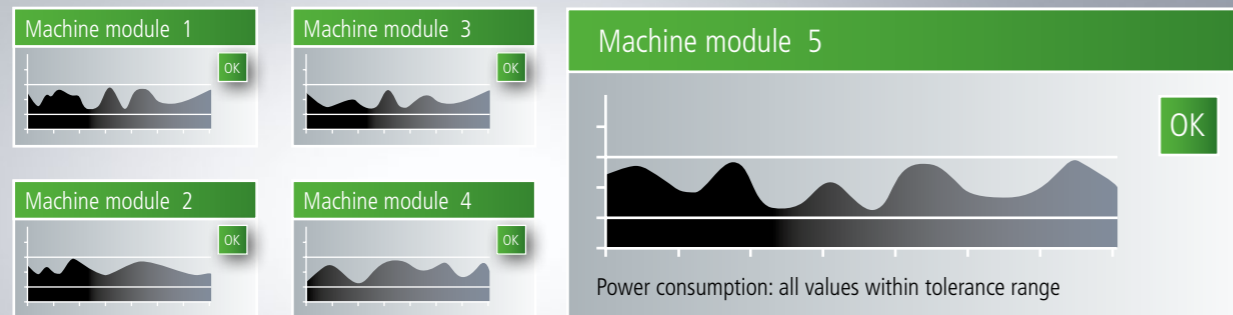



# System-integrated energy management with PC-based control

With a control solution from Beckhoff, the capture of energy measurements can be seamlessly integrated into the overall control system.

Energy measurement data from the field can be easily collected via the broad range of I/O modules available for this purpose. Gas, water and heat meters can be integrated into the system with impulse counters such as the EL1512 EtherCAT Terminal or Bus Terminals such as the KL6781 and KL6401 via M-Bus or LON interfaces. Compressed air usage can be measured and checked for wasteful leakages with the KM37xx differential pressure measurement terminals and the locally installed EP3744 IP 67 differen-

tial pressure measurement box. The KL/EL6224 series of terminals integrates I/O-Link-based sensors with great efficiency.

Existing power metering devices can also be integrated with ease, either directly over the corporate network via Modbus/TCP or via Beckhoff fieldbus couplers for all established systems such as PROFIBUS, PROFINET, M-Bus, Modbus RTU, EnOcean, and others.

The secure communication with optional cloud services is supported exclusively by outbound connections (MQTT, PubSub) which apart from that, can be protected with encryption and authentication mechanisms.



## Control system

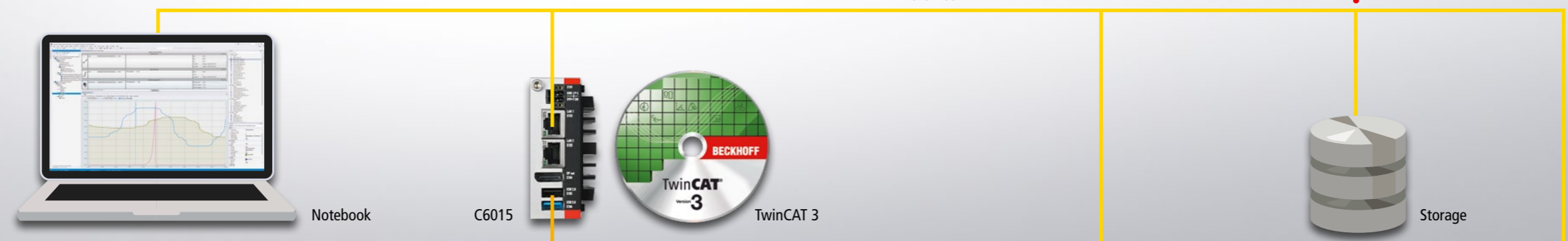

## I/O

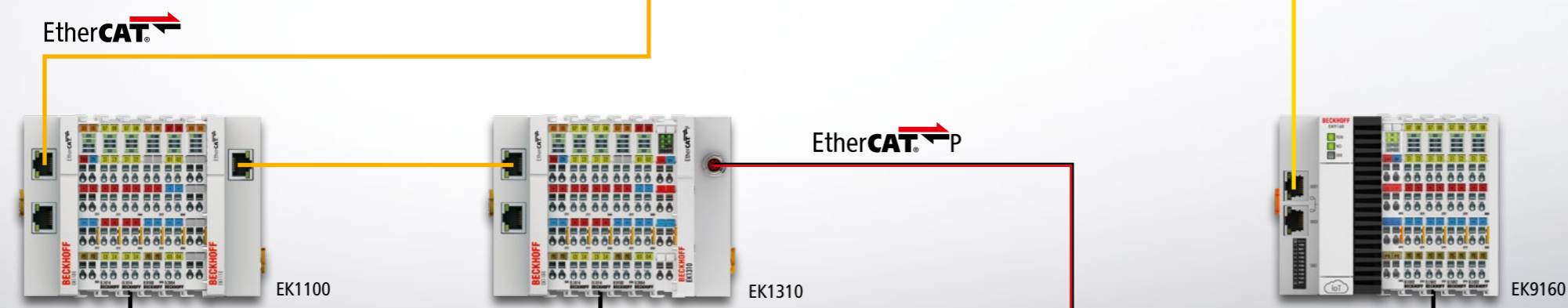

## Field





# Starting point of the Beckhoff measurement chain: SCT current transformers

With its SCT current transformers, Beckhoff makes it possible to implement reliable power sensor technology in the field which is directly integrated into the PC-based control system. Users can select from two device types, each with various designs and performance categories, that are highly scalable and therefore suitable for any application. The SCT portfolio is extremely broad-based, ranging from low-cost 3-phase CT sets for building technology to standard industrial transformers for machines through to solutions for inspection and test stands with extra-high accuracy requirements.

The choice of the product category depends on the type of use. While ring-type CTs are predestined for cost-effective and accurate data acquisition in new installations, split-core CTs provide the ideal solution for trouble-free retrofit solutions due to their easy installation.

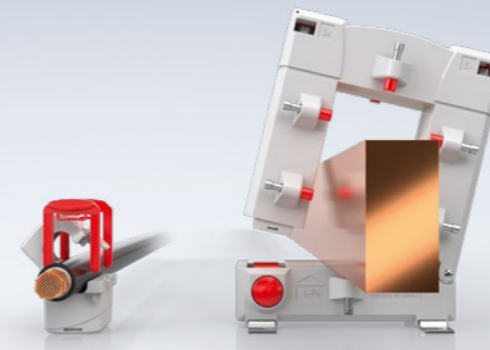

The SCT6xxx and SCT7xxx split-core models are ideal for flexible retrofits

## SCT current transformers:

- available as ring-type or split-core CTs
- for new installations and retrofits
- various designs and performance classes
- broad application range from buildings to test benches





# At a glance: the comprehensive power sensor portfolio



SCT1111



SCT21xx



SCT32xx



SCT61xx



SCT72xx

Accuracy classes	Ring-type current transformers								3-phase current transformer sets			Split-core current transformers for retrofits									
	Design	SCT01xx	SCT11xx	SCT21xx	SCT22xx	SCT23xx	SCT24xx	SCT25xx	SCT26xx	SCT31xx	SCT32xx	SCT33xx	SCT61xx	SCT63xx	SCT64xx	SCT66xx	SCT67xx	SCT71xx	SCT72xx	SCT73xx	SCT74xx
Primary nominal current in A	1	1/0.5																			
	2,5	1/0.5																			
	5	1/0.5																			
	10	1/0.5																			
	15	1/0.5																			
	20	1/0.5																			
	25	1/0.5																			
	30	1/0.5	1**																		
	35		1																		
	40		1																		
	50		1							1											
	60		1***	1						1			3								
	75			1									3								
	100			1						1	1*		3						3*		
	150			1/0.5						1/0.5	1*		3								
	200			1/0.5							1*			1/0.5					3*		
	250			1/0.5								1*		1/0.5					1*		
	300			1/0.5											1						
	400			1/0.5											1/0.5				1*/0.5*		
	500			1/0.5								1*			1/0.5					1*/0.5*	
600				1/0.5											1/0.5				1*/0.5*		
750				1/0.5											1/0.5					1*/0.5*	
800					1/0.5												1*/0.5*				
1000					1/0.5												1*/0.5*			1*/0.5*	
1250						1/0.5														1*/0.5*	
1500						1/0.5														1*/0.5*	
2000							1*/0.5*													1*/0.5*	
2500								1*/0.5*												1*/0.5*	
3000																				1*/0.5*	
4000																				1*/0.5*	
5000																				1*/0.5*	
Max. diameter round conductor	-	7.6 mm	25.7 mm	31.8 mm	43.7 mm	43.7 mm	54.7 mm	70 mm	13.5 mm	18 mm	22 mm	18.5 mm	18.5 mm	27.9 mm	42.4 mm	2 x 42.4 mm	20 mm	50 mm	80 mm	80 mm	

Notes: Standard: 1A secondary \* 5A secondary \*\* 32A primary only \*\*\* also 64A primary



# Broad performance spectrum: EtherCAT power measurement terminals

Scalability is a guiding principle of Beckhoff technology. This also applies to the EtherCAT power measurement terminals, which cover the entire range of applications from maintenance and closed-loop control to power monitoring. They are scalable for different performance categories in terms of precision and speeds ranging from seconds and milliseconds through to microseconds for oscilloscope functionality.

For basic measurement tasks such as monitoring of voltage, frequency and phases, Beckhoff offers the EL3483 as a mains monitor and the EL3423 for power measurements. Terminals in the EL34xx series handle measurements in

the lower ms range, e.g. for closed-loop machine control. The high-performance terminals of the EL37xx series enable high-end power monitoring by capturing instantaneous current and voltage values in  $\mu\text{s}$  resolution, e.g. in test racks.

Compared with the EL37xx series, the EL34xx series features much easier programming providing pre-scaled SI units, statistical analysis directly from the terminal, and a warning function when predefined upper and lower threshold values are exceeded. The EL37xx series enables particularly deep integration with its access to instantaneous current and voltage values in the PLC. The TF3650 Power Monitoring library simplifies the programming.

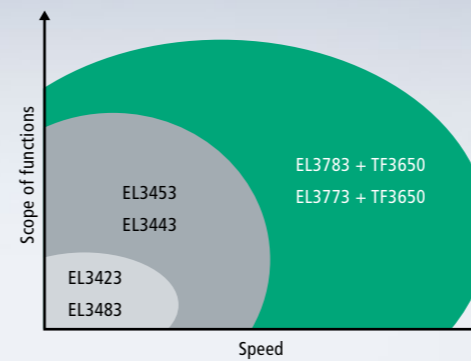

Application areas of Beckhoff power measurement terminals

## Management

	EL3483	EL3423	EL3483-0060
Voltage	480 V~	480 V~	480 V~
Current	–	1 A	–
DC-capable	yes	yes	yes
Meas. uncertainty U/I	–	max. 0.5 %	max. 0.5 %
Update time	100 ms	10 s	100 ms
Effective values	(U)	(U, I)	U
Power/energy	–	P, S, Q	–
Harmonics	–	–	–
cos $\phi/\lambda$	–/–	–/–	–/–
PQ factor	yes	yes	yes
Statistics/system status	yes/yes	yes/yes	yes/yes
1-bit system analysis	yes	yes	yes

## Management

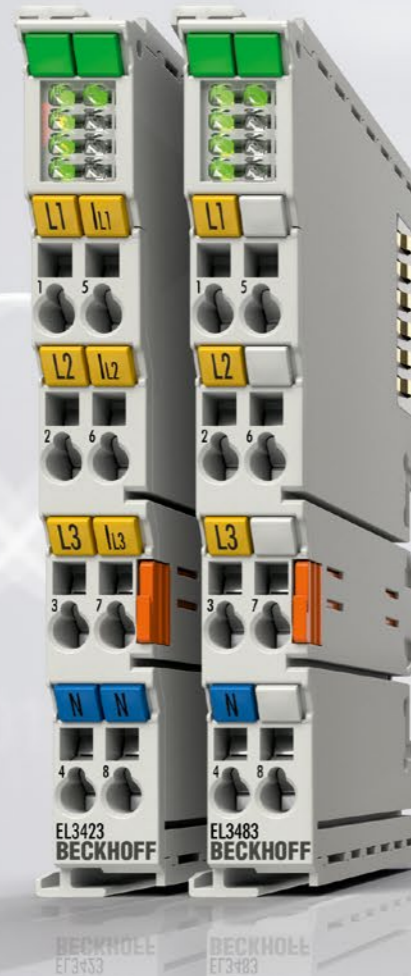

## Measurement

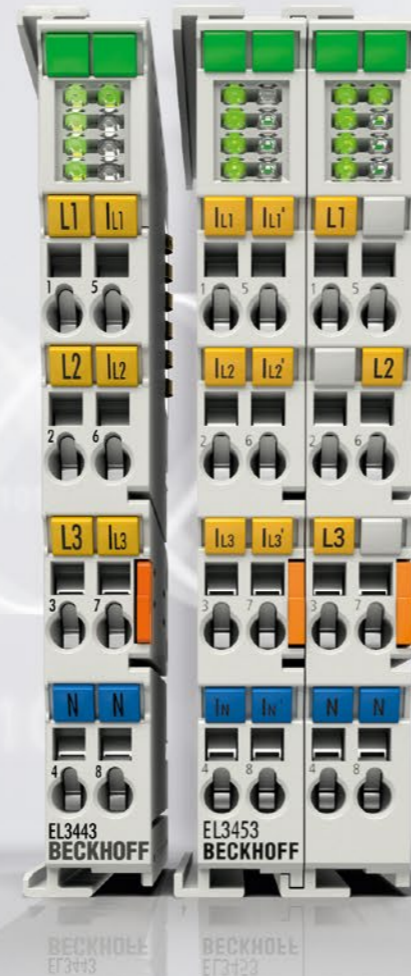

## Monitoring



## Measurement

	EL3443	EL3453	EL3446
Voltage	480 V~	690 V~ * 130 %	480 V~
Current	1/5 A	0.1/1/5 A * 130 %	1 A
DC-capable	yes	–	yes
Meas. uncertainty U/I	max. 0.3 %	max. 0.3 %	max. 0.3 %
Update time	20 ms	10 ms	20 ms
Effective values	U, I, (I <sub>IN</sub> )	U, I, I <sub>N</sub> , (I <sub>ERR</sub> )	U, I, (I <sub>IN</sub> )
Power/energy	P, S, Q	P, S, Q	P, S, Q
Harmonics	42	63	42
cos $\phi/\lambda$	yes/yes	yes/yes	yes/yes
PQ factor	yes	yes	yes
Statistics/system status	yes/yes	yes/yes	yes/yes
Elect. isol. current chan.	–	yes	–

## Monitoring

	EL3773	EL3783	TF3650
Voltage	480 V~	690 V~ * 130 %	–
Current	1 A	0,1/1/5 A * 130 %	–
DC-capable	yes	–	–
Meas. uncertainty U/I	max. 0.5 %	max. 0.2 %	–
Update time	100 $\mu\text{s}$	50 $\mu\text{s}$	–
Effective values	–	–	U, I, (I <sub>IN</sub> )
Power/energy	–	–	P, S, Q
Harmonics	–	–	~110
cos $\phi/\lambda$	–	–	yes/yes
PQ factor	–	–	yes
Statistics/system status	–	–	yes/yes
Elect. isol. current chan.	–	yes	–

*Speed + Precision*

# Special features: from peak detection to software configuration

The EtherCAT power measurement terminals open the door to many specialized functions, some of which are only available with Beckhoff and therefore may give you a competitive edge.

Apart from the functions described in detail below, they include features like min/max/average analysis, total power usage over preset intervals, and user-controlled input signals, as well as harmonics analysis of current and voltage up to the 63<sup>rd</sup> harmonic.

Also gaining importance is the measurement of fault or differential currents, which the EL3453 includes by default with its 4-current measurement channel (see figure on the right). This

feature can be used, for example, to find insulation faults before the power is switched off suddenly and unplanned.

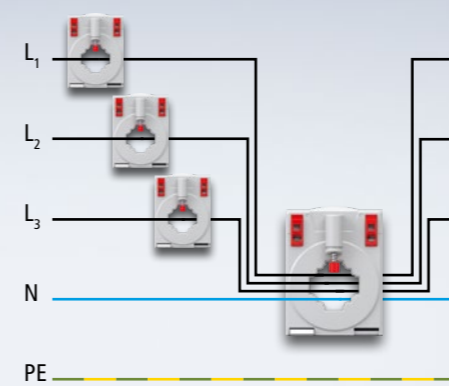

Differential current monitoring included: EL3453

## Special functions for power measurement:

- min/max/average evaluation and reporting
- total power usage for preset time intervals
- harmonics analysis
- detection of voltage peaks
- broad frequency measurement range
- zero-crossing detection
- software configuration
- calculated rest current

## Peak detection

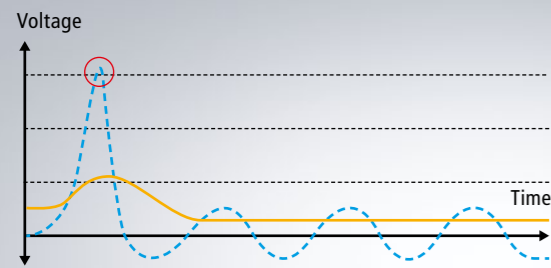

- recognition of maximum current and voltage values among measured values
- enables detection of harmful current and voltage peaks
- protects against data loss and hardware damage

## Response to LVRT voltage drop

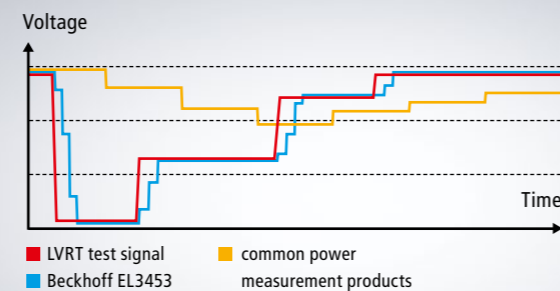

- Detecting short-term voltage drops in power grids, such as a low voltage ride through (LVRT), used to require expensive measurement technology.
- The diagram shows a comparison of the response times of Beckhoff Terminals and numerous third-party products to such events.

## Measurable frequency ranges

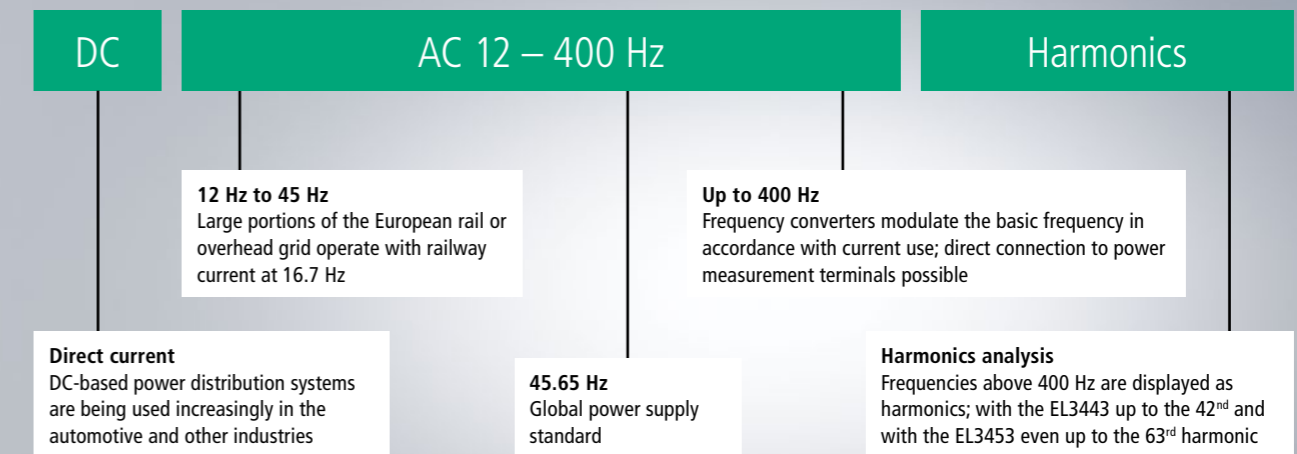

## Calculated rest current

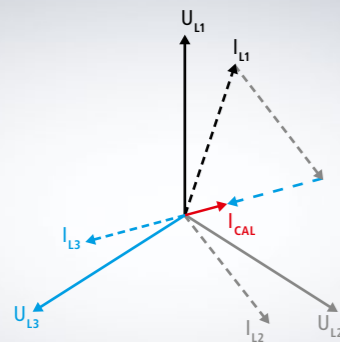

- additional current value calculated from the total of the instantaneous values of all measured currents
- fourth current measurement channel for the physical detection of the neutral conductor current or the differential current and/or fault current

## Software mapping

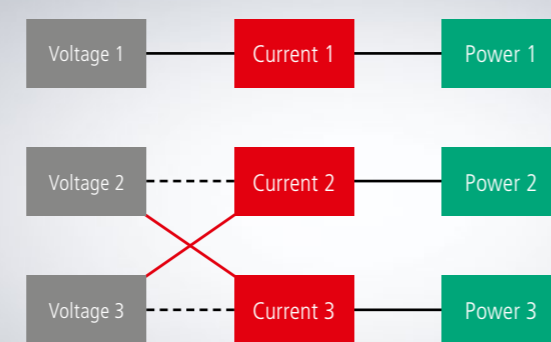

- software-configurable assignment of current and voltage paths
- phases 2 and 3 mis-wired; error can be fixed in software with CoE entry

## Zero-crossing detection

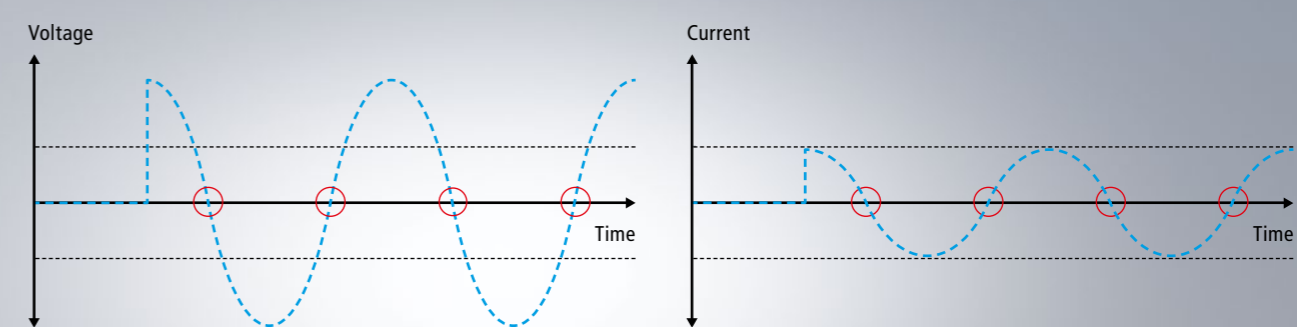

- Based on the EtherCAT distributed-clock system, the terminal determines zero crossings of voltage and current with an accuracy of 1  $\mu$ s.
- For contact-protecting switching, switching operations can be triggered by zero-crossing detection.
- Basis of the patented drift compensation process to keep distributed control systems synchronized without the need for additional connections. All that's required is measuring the zero crossings of the shared power installation via the power measurement terminals.



# Distributed power measurement: with the EL3446

Even if voltage and current measurement is carried out at different locations, real performance values can be determined via the distributed power management with the EL3446 Terminal. While the EL3446 can be used as a regular 6-channel power measurement terminal covering a range from 0 A to 1 A, it also features a innovation: Based on the EtherCAT-supported distributed clocks system, the EL3446 makes it possible to determine actual performance data, including the calculation of apparent, active and reactive power components, despite the physically separate measurement of current and voltage.

Voltage is measured only once by distributing the signal to all power measurement terminals, with time synchronization ensured by EtherCAT distributed clocks. The number of current measurements is arbitrary; the power is calculated by combining local current measurement values with the voltage values distributed over the EtherCAT network. No extra cabling is required for the voltage distribution. At the same time, the per-channel cost for power measurement is reduced significantly without having to reduce the sampling speed as the number of measurement points rises.

## Real power values despite separate measurements with the EL3446

- true power measurement data despite distributed measurement
- based on the EtherCAT distributed clocks system
- includes calculation of apparent, active and reactive power components
- one-time voltage measurement with synchronization via DC
- direct implementation with the EL3446

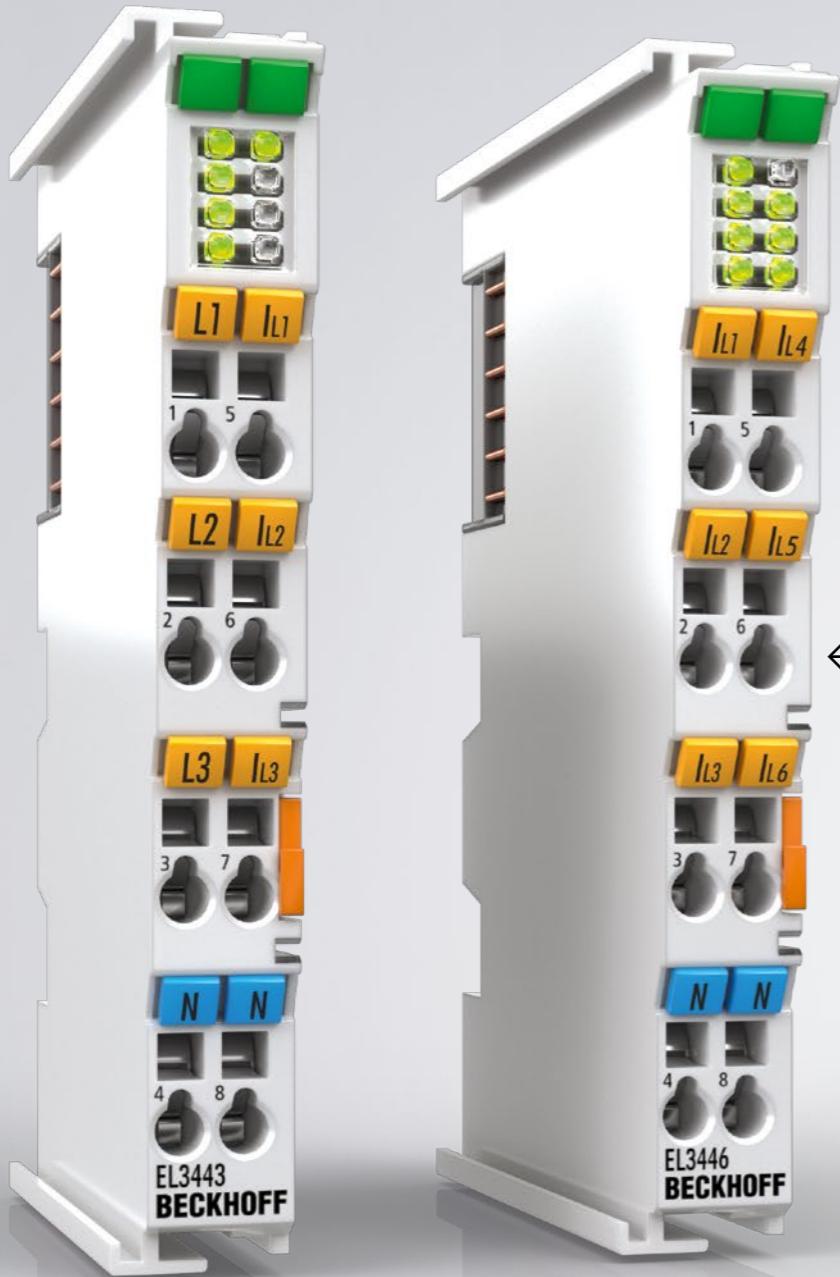

## Real performance values despite physically separate voltage and current measurement

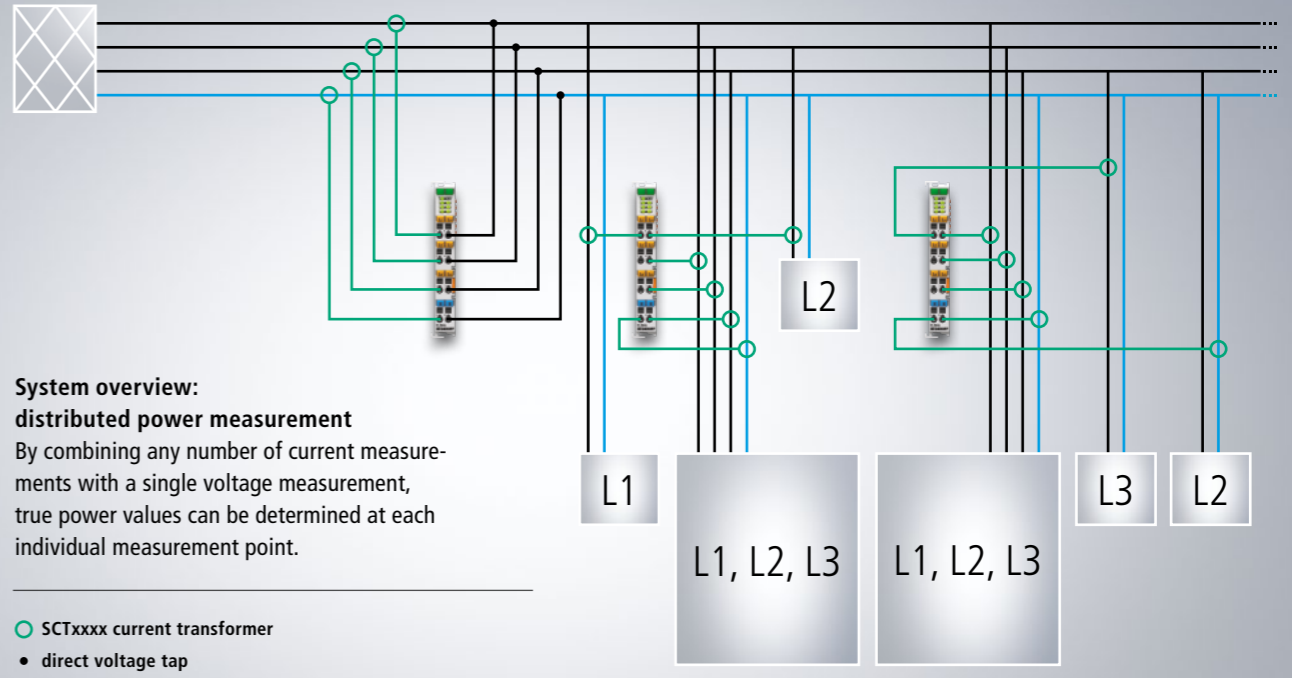

# Transmit energy data to the cloud reliably and easily with the EK9160

With the EK9160 Bus Coupler, EtherCAT I/Os can be linked directly to the IoT without the need for a separate control program. By autonomously transferring the E-bus signal representations to various IoT communication protocols, the IoT Coupler makes it possible to integrate I/O data into cloud-based communication and data services easily and in a standardized manner.

Neither controller nor programming is needed. Users can configure the I/O data in a simple dialog with the integrated web server using any browser. The respective cloud service and security functions such as authentication,

encryption, etc. can also be easily configured via the browser. Once the parameters have been set, the Bus Coupler sends the digital or analog I/O values, including the associated timestamps, to the cloud service. If the internet connection is interrupted, the I/O data can be buffered locally.

### Direct cloud connection via the EK9160:

- no controller or programming required
- easy, reliable and direct IoT connectivity via standard communication protocols
- automatic transmission of I/O values including timestamps
- automatic local buffering protects data if the internet connection is interrupted

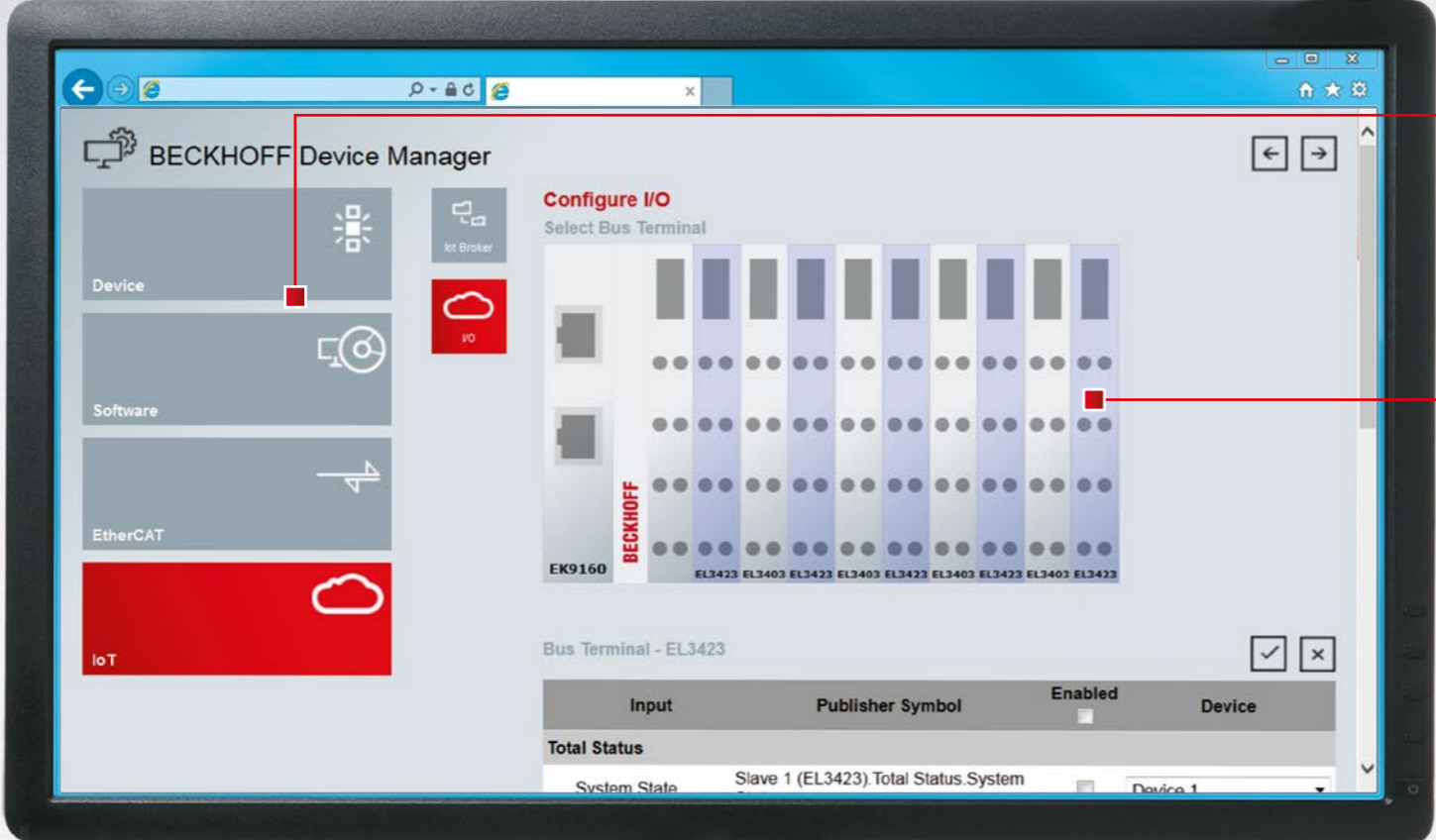

### Cloud configuration

- Parameterize cloud connectivity
- Select an authentication process
- Configure an encryption process

### Terminal configuration

- Select from all available input and output values for each I/O terminal with no programming
- Change configuration directly on terminal level





# Cloud-based data analysis for power management with TwinCAT

Fast, cloud-based analysis of their power data allows users to optimize their power management. With TwinCAT Analytics, all data can be analyzed as needed, either point-by-point or continuously. While the TwinCAT Analytics Service Tool improves and simplifies the commissioning processes for technicians, the Workbench features enhanced capabilities and also makes automatic generation of program code possible. And with 24/7 runtime deployment, the Workbench enables consistent and seamless data analysis. This way, machine manufacturers can offer their customers individual data analytics solutions and become themselves

providers of new predictive maintenance concepts for an improved power management system.

### Cloud-based data analytics:

- integrated with TwinCAT Analytics
- simple data storage and analysis
- many easy and useful algorithms
- automatic code generation
- custom analytics dashboards

## TF6720 | TC3 IoT Data Agent

The TC3 IoT Data Agent provides bidirectional IoT communication functions in the form of a gateway application that can be configured and operated separately from the TwinCAT real-time environment.

The Data Agent picks up configured process data on its own and transmits it to a communication or data service in the Microsoft Azure or Amazon Web Services (AWS) cloud. Alternatively, it sends the process data based on MQTT or AMQP to a message broker. To pick up the process data, both the TwinCAT ADS and the OPC UA IEC standard with their security mechanisms are available. This ensures that the data is protected down to the controller or the respective end device.

To reduce the amount of traffic and associated costs, the data agent supports advanced sampling mechanisms such as on-data-change transmissions.

If the connection is broken, buffering algorithms are available to prevent the loss of data. The Data Agent is configured via a graphical editor, which makes it much easier to use and speeds up the commissioning of the system.

► [www.beckhoff.com/TF6720](http://www.beckhoff.com/TF6720)

## TE3500 | TC3 Analytics Workbench

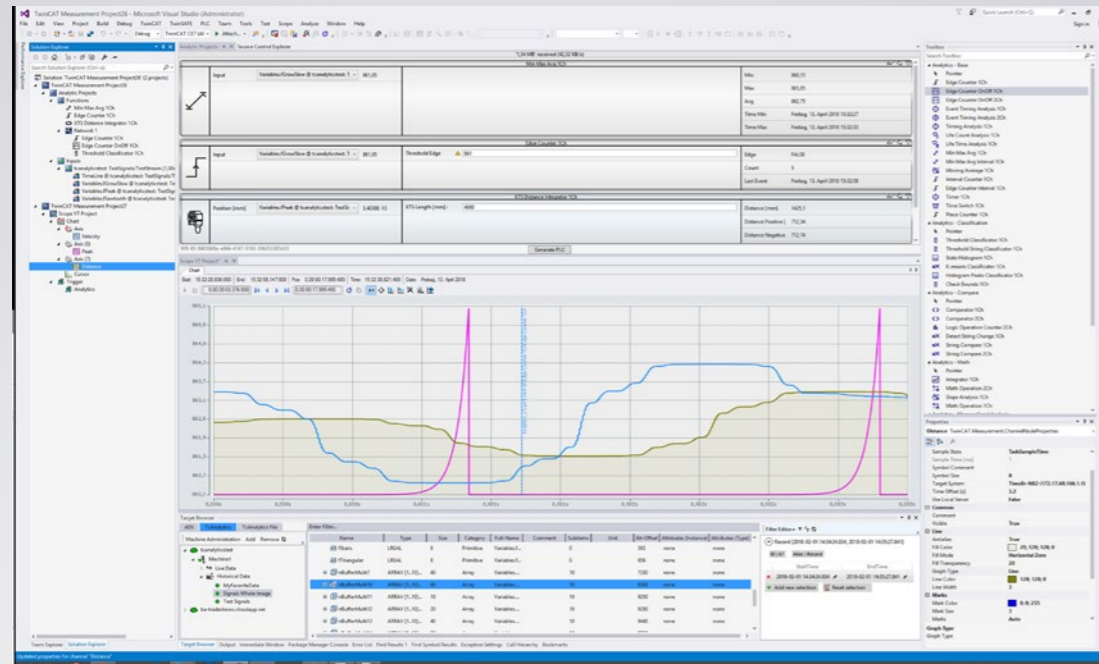

The TE3500 Analytics Workbench engineering product allows continuous data analysis based on multiple and spatially distributed sources. The ability to design individual dashboards on the basis of TwinCAT 3 HMI rounds out this software package. To configure an individual analysis, a graphical editor provides a large number of useful algorithms that can be simply dragged-and-dropped. The key aspect in this regard is the intuitive operation of the configurator, which is integrated in Microsoft Visual Studio® as a TwinCAT-independent project. The presentation of the algorithms is split into three areas: inputs, parameters, and outputs. The MQTT input data is selected via the TwinCAT target browser, with live data and historical data available via the Analytics storage provider. Following the configuration, which can be structured very clearly even across different networks,

the results can be displayed directly in the graphical editor. Once the analysis is complete and tested, the configuration can be converted into readable PLC code with a single mouse click. The automatically generated PLC code can be downloaded directly onto a device with Analytics Runtime to run 24/7 and deliver analytical results in parallel with the actual data source, i.e. the production machine. The structured text being generated can be enhanced individually by the application developer, because it is in a programming language that is already known to the user from the respective machine application. Using standard Beckhoff PLC libraries is also possible.

► [www.beckhoff.com/TE3500](http://www.beckhoff.com/TE3500)

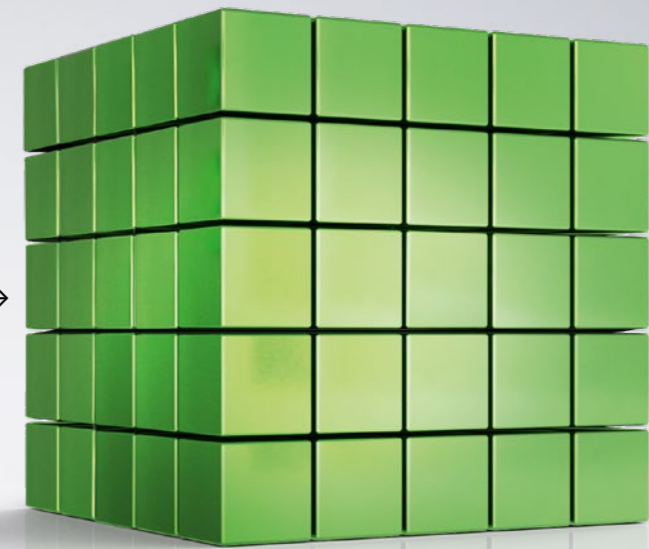

## TF3650 | TC3 Power Monitoring

TwinCAT Power Monitoring is a PLC library for analyzing raw current and voltage data that has been captured and supplied by the EL3773 and EL3783 EtherCAT terminals. It provides function blocks for calculating RMS values for current, voltage and performance that can be output as instantaneous or average values. The function block also provides minimum and maximum values. Frequencies and frequency spectrums as well as harmonics

can be determined on the network, and their load can be determined in the form of total harmonic distortion (THD).

All function blocks are available for 1-phase and 3-phase systems. To display and/or store the data, the TE1300 TC3 Scope View Professional and the TF6420 TC3 Database Server are available.

► [www.beckhoff.com/TF3650](http://www.beckhoff.com/TF3650)



# References

To remain competitive in the global market, PCB assembly specialist Smyczek decided to cut operating costs by installing a comprehensive energy management system.

- Integration into the existing company IT
- Easy capturing of data from various energy carriers
- A monitor on the shop floor provides an overview of all lines
- Reduction of (unscheduled) downtime

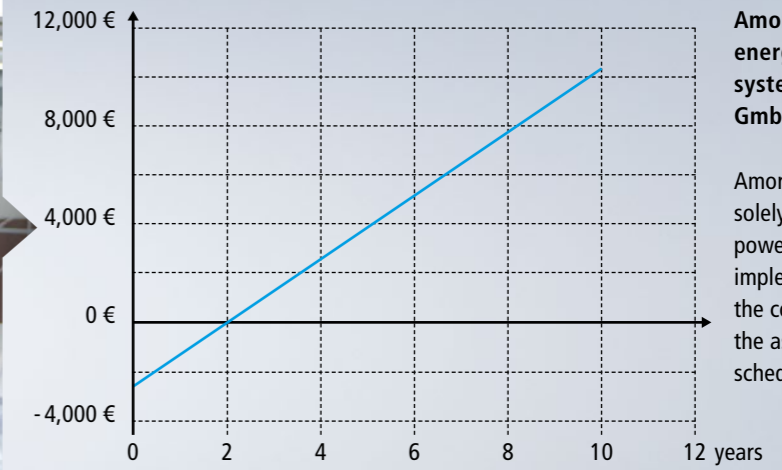

**Amortization of the energy management system at Smyczek GmbH & Co. KG**

Amortization calculation solely based on the first power-saving measure implemented, which is the complete shutdown of the assembly line during scheduled downtimes.



**Modular and open control solution provides connectivity for wind turbines (ee Technik GmbH)**

- Preventing grid failures as well as voltage and frequency drops requires a properly planned electrical infrastructure, e.g. in large wind farms.
- Based on the open and integrated control architecture from Beckhoff, controllers for decentralized generation systems can be optimally adjusted to the respective application case.



See PC Control article here:



**12 megawatt power storage system regulates frequency (Power21)**

- Integrated control platform for power management and power conversion systems as well as for power storage system
- EtherCAT delivers high-speed frequency capturing and response times
- Detection of frequency changes within 20 ms; frequency resolution of 0.1 mHz
- Power storage system receives new voltage values from EtherCAT XFC terminals every 0.2 ms



See PC Control article here:



**PC-based control technology combines energy data acquisition with big data analysis (regio IT GmbH)**

- Energy management requires monitoring with the shortest time intervals possible.
- Consumption of water, power and heat is metered by regio IT GmbH.
- Beckhoff hardware in full-service data logging solution of e2watch monitoring system
- Approx. 100,000 datasets/day via TwinCAT 3 OPC UA Server.

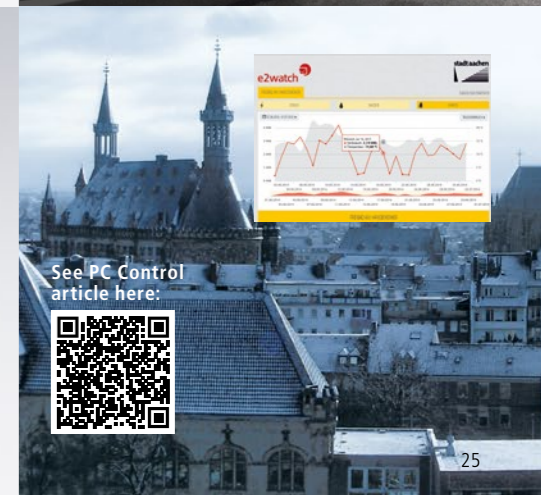

See PC Control article here:





# In use all over the world: Energy management systems from Beckhoff

**New Automation Technology**  
 Beckhoff implements open automation systems using proven PC-based control technology. The product spectrum comprises these main areas: industrial PCs, I/O and fieldbus components, drive technology and automation software. Product lines are available for all areas and can be used as either individual components or as a complete system solution. The Beckhoff "New Automation Technology" philosophy stands for innovative

and open control and automation solutions that are used worldwide in a diverse variety of applications ranging from CNC machine tools to intelligent building automation systems.

**Globally present on all continents**  
 Beckhoff is present in 75 countries, providing globally active customers with rapid service worldwide and technical support in their local language. Moreover, Beckhoff sees close proximity to customers as a prerequisite for an in-depth understanding of the technical challenges they face.

- Beckhoff Automation at a glance**
- 2023 global sales: €1.75 billion (+16 %)
  - Headquarters: Verl, Germany
  - Managing owner: Hans Beckhoff
  - Employees worldwide: 5,500
  - Engineers: 2,000
  - Subsidiaries/representative offices worldwide: 40
  - Sales offices in Germany: 23
  - Representatives worldwide: > 75

**Further information**  
 Additional Beckhoff catalogs and flyers are available to download on the Internet.  
 ► [www.beckhoff.com/media](http://www.beckhoff.com/media)

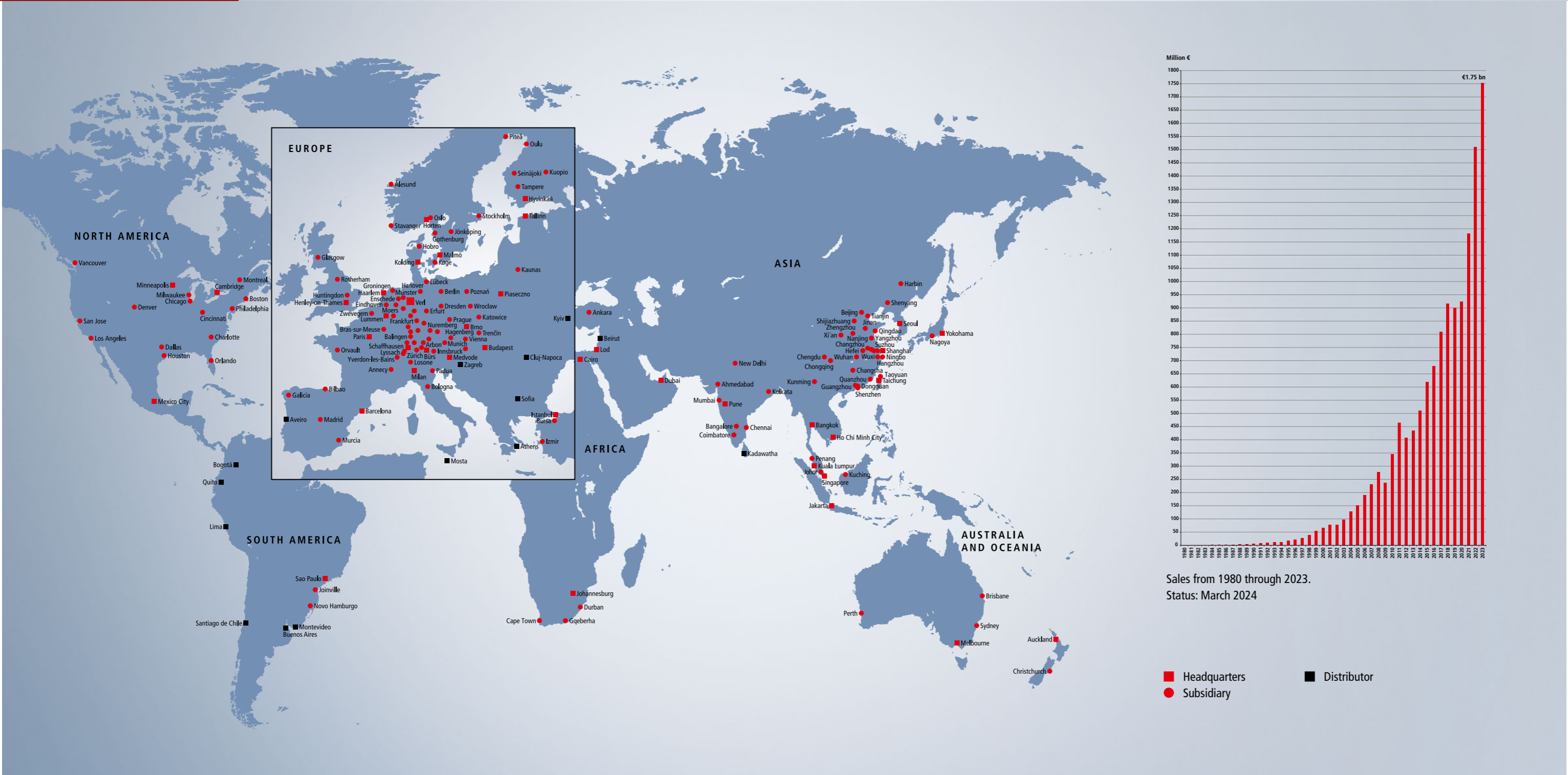



How can we improve your energy management?  
Talk to us.

► [www.beckhoff.com/energy-management](http://www.beckhoff.com/energy-management)

**Beckhoff Automation GmbH & Co. KG**

Huelshorstweg 20

33415 Verl

Germany

Phone: + 49 5246 963-0

[info@beckhoff.com](mailto:info@beckhoff.com)

[www.beckhoff.com](http://www.beckhoff.com)

Beckhoff®, TwinCAT®, EtherCAT®, EtherCAT G®, EtherCAT G10®, EtherCAT P®, Safety over EtherCAT®, TwinSAFE®, XFC®, XTS® and XPlanar® are registered trademarks of and licensed by Beckhoff Automation GmbH. Other designations used in this publication may be trademarks whose use by third parties for their own purposes could violate the rights of the owners.

© Beckhoff Automation GmbH & Co. KG 04/2024

The information provided in this brochure contains merely general descriptions or characteristics of performance which in case of actual application do not always apply as described or which may change as a result of further development of the products. An obligation to provide the respective characteristics shall only exist if expressly agreed in the terms of contract.

We reserve the right to make technical changes.

Picture Poof: ee technik GmbH | Power21 | regio IT GmbH