

BECKHOFF

# PCcontrol

The New Automation Technology Magazine

No. 3 | September 2025

[www.beckhoff.com/pc-control](http://www.beckhoff.com/pc-control)



46 | worldwide

## Automation ensures safe pyrotechnic effects in sync with live music



ATRO.

6 | products

Automation Technology for Robotics: The future of robotics is modular



38 | worldwide

PC-controlled injection molding: highly precise and flexibly adaptable to the latest IoT trends

news



4 | Hans Beckhoff receives the Rudolf Diesel Medal for Most Successful Innovation Achievement

products

6 | Automation Technology for Robotics (ATRO): The future of robotics is modular

worldwide



12 | Carl Benzinger, Germany: A vision-based, AI-supported system for shining rings

16 | Chiron, Germany: CNC machine with an increased working space but same dynamics and precision



20 | Vetex, Germany: Computing power and integrated stepper motor drives increase quality and availability in the carpet production

24 | Synhelion, Germany and Switzerland: Reliable production of ecofuels from solar energy with PC-based process control technology

28 | Hebetec und Elpex, Denmark and Switzerland: EtherCAT-based control technology for transporting gigantic tunnel elements

32 | Siemens Gamesa Renewable Energy, Denmark: Automated converter testing for next-generation wind turbines

36 | ruhlmat Huarui, China: Producing large quantities of flat wire motors for electric vehicles flexibly and efficiently

38 | Nissei Plastic, Japan: PC-controlled injection molding: highly precise and flexibly adaptable to the latest IoT trends

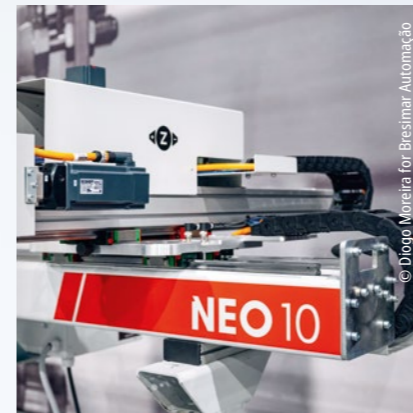

42 | INAUTOM Robótica, Portugal: Controlling cartesian robots dynamically and precisely

46 | Image Engineering, United States: Advanced automation technology ensures safe pyrotechnic effects in sync with live music

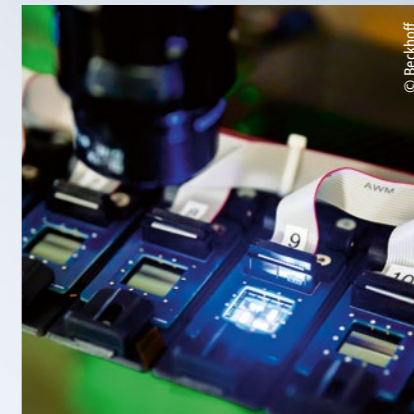

50 | OTI Lumionics, Canada: OLED material development with triple the throughput at nanometer-precise deposition rates

54 | Additive Industries, Netherlands: Open control solution combines precision with graphical programming

58 | Reelables, United Kingdom: PC-based control for scaling the production of tracking labels

ETG

62 | Semiconductor Technical Working Group: Strong momentum, new profiles, and a look ahead

EtherCAT worldwide: Successful roadshow in Brazil

63 | Safety over EtherCAT Plug Fest in Leinfelden-Echterdingen

imprint

PC Control – The New Automation Technology Magazine

Published: Beckhoff Automation GmbH & Co. KG  
Hülshorstweg 20  
33415 Verl/Germany  
Phone: +49 (0) 5246 963-0  
info@beckhoff.com  
www.beckhoff.com

Project management/editor: Stefan Ziegler

Editors: Stefan Kuppinger  
Vera Nosrati

Phone: +49 (0) 5246 963-140  
editorial@pc-control.net  
www.beckhoff.com/pc-control

Graphic Design: www.a3plus.de

Printed by: Richter Druck- und Medientcenter, Germany

Circulation: 23,350





© Dominik Wagner, Eichmeister Kreativagentur

The Rudolf Diesel Medal honors inventiveness and the skill that it takes to make innovations economically successful. Hans Beckhoff was awarded this prestigious medal at the award ceremony held at the MAN Museum in Augsburg on July 10, 2025. This medal, in the Most Successful Innovation Achievement category, honors him as an inventor and entrepreneur in automation technology: Prof. Dr. Alexander J. Wurzer, member of the board of the German Institute for Inventions, Hans Beckhoff of Beckhoff Automation, the recipient of the Rudolf Diesel Medal, Prof. Dr. Gunther Herr, laudator, Professor of Comprehensive Business Innovation Strategies at Steinbeis University Berlin and Scientific Advisor to the Diesel Medal Board of Trustees (from left to right).

Since the company was founded in 1980, Beckhoff's ethos has consistently been reflected in the company's technological innovations and revolutions, many of which have developed into global market standards in automation and have thus had a lasting impact on the industry.

Hans initiated a paradigm shift in automation with the PC-based control technology concept in 1985 and launched it on the market in 1986. This technology revolutionized previous principles and made the family-owned company a major player in the SME sector. With his tireless commitment to innovation and ability to turn visionary ideas into a commercial success, Beckhoff's company has become a leading technology manufacturer in the automation technology field. He consistently shapes the industry with innovative solutions and sets new standards that further the integration of IT technologies into automation. Beckhoff currently employs around 5,300 people across 41 subsidiaries and representative offices worldwide, achieving sales of €1.17 billion in 2024.

Prof. Dr. Gunther Herr, Professor of Comprehensive Business Innovation Strategies at Steinbeis University in Berlin and scientific advisor to the Diesel Medal Board of Trustees, attributes these 45 years of success to Beckhoff's technological and entrepreneurial foresight, his innovative, pioneering thinking, and his unstinting creativeness. He has built up an owner-managed company that is supported by people-centered values and is above all characterized by trust and the courage to innovate. With PC-based control, Beckhoff has established automation as the foundation technology for products across many sectors of society and constantly pushes performance limits throughout the industry.

Beckhoff technology is characterized by software-based rather than hardware-based control technology, integration of IT and automation technology, ultra-fast and reliable communication technology, highly optimized drive technology and deep embedding of AI functionality. It is successfully used by many customers worldwide to control the latest manufacturing machinery, buildings, technical processes, scientific experiments and big stage shows to name a few.

#### Beckhoff's message to the next generation: "Inventing is fun"

"I feel very honored and want to thank the Board of Trustees for this honor," says Hans Beckhoff and goes on to explain. "We've aimed to present evolution-

ary technologies every year and launch a real revolution on the market every five to seven years since the company was founded in 1980. I've held fast to this guiding principle for 45 years now." He then gave his take on being an innovator: "The world is a big, diverse space that offers a lot of opportunities. As an entrepreneur, all you have to do – and this is easier said than done – is seize your chance, recognize pioneering technologies and trends, and generate progress with your own inventions. I'm proud of our innovative spirit and the technologies that have come from it." In his acceptance speech at the award ceremony, Hans Beckhoff said: "The Rudolf Diesel Medal that has been given to me today is, of course, not for me alone – it has been awarded to our entire company. Over 600 developers and product managers work in development every day, looking to create new advanced automation products. Over 2,000 employees worldwide work closely with customers, support our users, and listen to their wishes and requirements. Our customers have therefore also contributed to our success as an inventing company, through their feedback on our products, and through their own ideas. This collaborative partnership sets us apart and brings us great joy." Hans Beckhoff and his company are currently working on the Automation Brain, which is intended to give machinery its own intelligence and personality, similar to the human brain. "There's still a lot of potential for innovation in automation," he emphasizes.

He also has a message for the next generation of engineers: "Inventing is fun. That eureka moment, when an idea takes shape and becomes clear, or when something works for the first time is a wonderful experience. Don't give up and keep working on your inventions – it's worth it, just for that moment alone!"

Prestigious award recognizes inventiveness and entrepreneurial courage

## Hans Beckhoff receives the Rudolf Diesel Medal for Most Successful Innovation Achievement

Hans Beckhoff, Managing Director and founder of Beckhoff Automation, a technology company headquartered in Verl, was honored with the widely acclaimed Rudolf Diesel Medal 2025. Hans Beckhoff received this prestigious award in the Most Successful Innovation Achievement category at the award ceremony held at the MAN Museum in Augsburg on July 10. This medal honors him as a visionary pioneer in automation technology.

The Rudolf Diesel Medal is one of the most renowned and long-standing awards for pioneering achievement in Europe. It recognizes the significance of the culture of innovation in Germany and honors inventiveness and entrepreneurial courage. It is awarded by the German Institute for Inventions (Deutsches Institut für Erfindungswesen, D.I.E. e.V.) and honors people and companies that have made a significant contribution to society by improving quality of life, prosperity, and preserving the culture of innovation in Germany, thus inspiring the next generation of engineers and entrepreneurs.

#### Hans Beckhoff: An innovative pioneer who shapes industry

The Rudolf Diesel Board of Trustees, which consists of around 60 leading technology directors and managing directors of medium-sized global market leaders, has recognized Hans Beckhoff as a visionary pioneer who embodies the values of the Rudolf Diesel Medal through his corporate principles and strong social engagement. The jury honored Hans Beckhoff in the Most Successful Innovation Achievement category. This category focuses on innovative prowess and the company's overall impact on the economy.

More information:

[www.rudolf-diesel-medaille.de](http://www.rudolf-diesel-medaille.de)

[www.beckhoff.com/technological-milestones](http://www.beckhoff.com/technological-milestones)

The modular ATRO industrial robot system makes it possible to implement application-specific robot solutions that are seamlessly integrated into TwinCAT.



**ATRO**®

ATRO: Automation Technology for Robotics

# The future of robotics is modular

**BECKHOFF BECKHOFF**



**XPlanar**®

Can you imagine having the right robot ready on the shelf for every handling task around your machine? A small machine type might require a robot with a short reach to insert new, relatively heavy parts. In another type of machine, you might want to stack the finished products on a pallet – this time requiring a large reach. Yet another machine involves a simple, fast pick-and-place application from a fixed infeed to a moving conveyor belt. You are unlikely to always have the right robot to hand for all of these variants. But if a customized robot can be freely assembled from existing standard modules for each task – as with the modular ATRO system from Beckhoff – you can achieve the necessary flexibility without a great deal of effort.

The modularity of the ATRO system from Beckhoff therefore results in concrete advantages for the user. After all, a 6-axis articulated robot is not always the right tool for the job. In many pick-and-place scenarios, just three or four degrees of freedom are enough, which means fewer axes, lower costs, and reduced weight – and these weight savings can then be used to offset a higher payload. The same ATRO motor and link modules can be used to create a wide variety of kinematic designs, which reduces variance in the inventory and increases flexibility.

**High flexibility through modularity**

The ATRO system is a modular industrial robot system that can be used to put together optimized robot structures for different applications in the field of assembly and handling technology on an individual and flexible basis. Standardized motor modules with integrated drive functionality, together with link modules in various designs and lengths, allow for virtually limitless mechanical combinations. Furthermore, complete integration into the holistic TwinCAT control platform offers direct access to a wide range of proven automation functions. An integrated PC-based platform for machine control, robot control, safety, vision, condition monitoring, or connection to an edge device or cloud system integrates all functions.

Wouldn't it also be helpful if the external supply lines to the end effector could be omitted? This would mean that they would not be constantly in the way and would also eliminate the need to replace them regularly due to the torsional stress. And without these cables, endless rotation of all the robot's axes would

be a possibility. All ATRO modules offer an internal media feed for data and electrical supply plus two fluid channels for this very purpose. The desired media can be fed in at the base of the robot and are conveyed through the motor and link modules to the end effector. The active motor modules were designed in such a way that endless rotation of all axes remains possible.

ATRO combines modularity and flexibility in an industrial robot system with an internal media feed and endless rotation in all axes, and is integrated into the PC-based machine control system. The ability to (re)use identical module types across various configurations helps cut storage costs and reduces the need for spare parts.

**General requirements and properties**

A robot is regarded as partly completed machinery as it cannot usually fulfill a specific function without additional components such as tools, sensors, or safety devices. Only when a robot is installed in a machine and equipped with the necessary components does it become a complete machine. In compliance with the European Machinery Regulation EU 2023/1230, which also applies to partly completed machinery, the health and safety requirements must be guaranteed by the manufacturer. The European harmonized standards DIN EN ISO 10218-1 and DIN EN ISO 10218-2 apply to the safety of industrial robots. New versions of these standards were published in early 2025 and will soon take effect once harmonization is complete. As of the end of the transition period (expected in 2027), they will apply to all industrial robots that are new on the market.

If a machine builder puts together their desired robot configuration using ATRO modules and integrates this system into their machine, they must meet the requirements of ISO 10218-2 for the robotic portion of the application. In addition to the hardware modules for the kinematics, the ATRO system also offers software modules that – in combination with pre-tested safety templates – meet precisely these requirements.

**Versatile and easy-to-install mechanical system**

Each ATRO motor module represents a complete drive system for one axis or joint of the robot. The system comprises a decentralized 48 V EtherCAT drive with brake, gearbox, and Safe Motion functions. This means that the only external components required are a power supply and a control system, which significantly reduces the space required in the control cabinet.

In addition to the active motor modules, there are mechanically passive modules which can be used to create the design of the robot configuration. The modules are assembled by simply screwing them together, whereby the ATRO interface provides a robust mechanical connection and also connects the internal media feed. This means that assembly can be carried out by a single person and individual modules can be exchanged effortlessly, e.g., for maintenance purposes.

The base modules allow the robot to be mounted on a base plate, a wall, or the ceiling. The connection to the internal media feed can be implemented at the side or at the bottom. The tried-and-tested hybrid connectors, which provide both electrical power and EtherCAT or Ethernet communication, allow simple plug-in connection. The robot's 48 V supply is stabilized in the base by a brake chopper with resistor.

The link modules are offered in different shapes and lengths to form the "arms" of the robot. Since they, like all ATRO modules, are EtherCAT devices and come with their mechanical properties as an electronic type plate, the chosen configuration can be scanned by the controller in order to select the correct calculation rule for motion control.

The ATRO interface also serves as an interface to the tool on the end effector. For adaptation to grippers with an ISO interface, a flange module is offered that routes the internal media to pluggable contacts. A flange set with ATRO interface is available for manufacturers who wish to fully integrate their tools.

Dr. Guido Beckmann,  
Product Management  
ATRO and EtherCAT,  
Beckhoff Automation



**Machine and robot control become one**

One of the main tasks in integrating robots into a machine or system has so far been to successfully manage the interfaces between the systems: The robot controller must be connected to the machine control system, and both require further automation functions such as vision or coordinated motion functions. For highly dynamic applications, the integration of these systems must be based on real-time-capable interfaces. The movement of the machine axes can

Various motor and link modules are available in the ATRO system, which can be used to create application-specific kinematics.

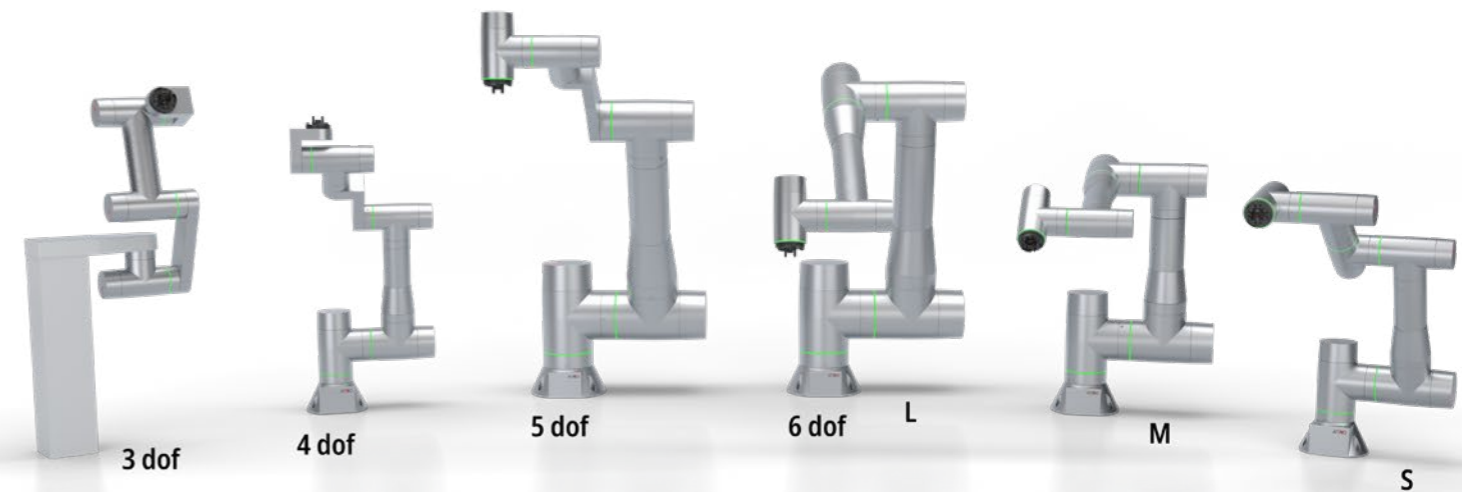

Just a small selection of possible ATRO kinematics

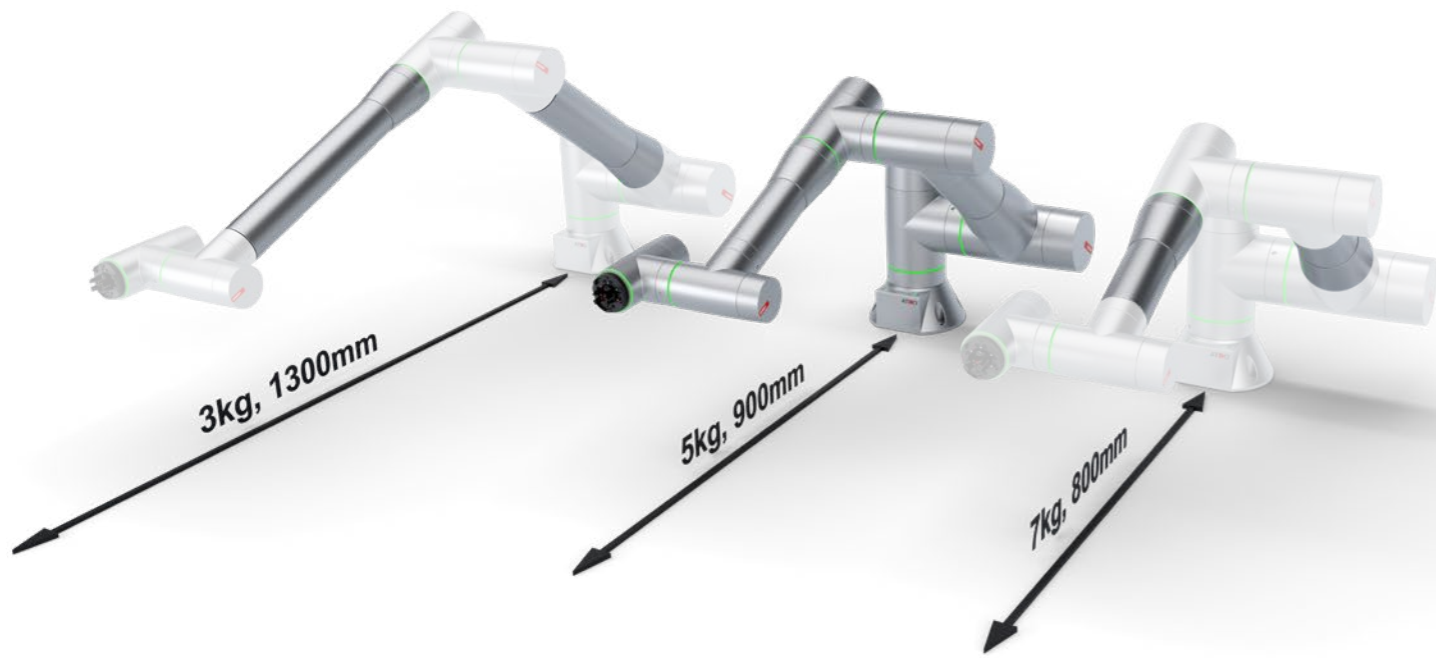

The possible payload of a robot configuration is directly related to the selected arm length, i.e., the possible reach.

then be coordinated with the tool at the robot end effector and synchronized with the detection of the product from the camera.

The TwinCAT automation platform combines all these functions in a PC-based control system. This means that up-to-date information from all functions is available to every device at the same time for processing. This also incorporates information and states regarding the functional safety of the system



**Thomas Rettig,**  
Product Management  
ATRO and EtherCAT,  
Beckhoff Automation

and the robot, which until now has often been coupled to the system via safe I/O signals.

The robotics integration in TwinCAT includes the configuration of the modular kinematics on the one hand and the motion control programming functions on the other. A 3D visualization tool supports the configuration of the modular kinematics. Here, all types of ATRO modules can be selected to form the desired combination. By importing STEP files, the embedding of the robot in the machine environment can also be visualized. The configuration can then be loaded into the TwinCAT development environment. At the same time, all necessary preparations and links are automatically created in the TwinCAT system so the user can start programming motion control directly.

If there is an online connection to the real controller, the 3D representation can also be used as a live view of the current robot pose and movement or as a simulation view.

An extensive robotics library is available to facilitate programming. The library abstracts the individual modules into a robot instance on which the necessary parameters – such as length, mass inertia, dynamic model, and also the transformation equations – can be parameterized. This robot instance can be operated using simple movement commands.

An intuitive user interface has been developed for commissioning and operating the robot. This interface provides visualization elements based on TwinCAT HMI that enable standard-compliant operation of the robot, e.g., for jogging the individual axes or in Cartesian coordinates.



ATRO is fully integrated into the TwinCAT platform.

The 3D visualization, which has already been used for configuration, can be found here as an online view. Vision controls or, for example, scope controls for displaying continuous signal curves can also be embedded.

Task-specific functions can be individually displayed using an app concept. There are functions for moving the robot and for saving or editing waypoints. In another application, movement and gripper commands can be combined with wait states to create simple sequence programming. Complex motion programming can also be carried out in a similar way on the programming computer or, of course, in the familiar PLC environment, i.e., integrated into the machine programming.

As web-based display based on HTML5 is used, the interface can be displayed using a browser, e.g., on a machine panel, a tablet, or a teach pendant.

The necessary safety functions from ISO 10218-1:2025 include various safe stop functions as well as safe monitoring of the Cartesian speed of the tool center point (TCP) and exposed areas of the robot, e.g., the elbows. Beckhoff uses the TwinCAT Safety PLC for this purpose, which provides SIL3 safety logic on standard Beckhoff Industrial PCs. On this basis, function blocks are offered which monitor a safe Cartesian speed of the TCP and other exposed axes based on the safe individual axis positions of the ATRO motor modules. Application examples of these function blocks, which have been approved by a notified body, also help the user to achieve the necessary safety level for their application.

**Conclusion**

The end-to-end modularity of the ATRO system – both in its hardware modules and software modules for configuration, programming, operation, and safety

monitoring – opens up a whole new level of flexibility for user applications. In addition to classic serial robot kinematics, exciting new configurations can be put together from the modular system by simply adding passive link modules: Due to the option of endless rotation in axis 1, workstations can be reached in the most effective way and always via the shortest route. An additional T-module after the first axis enables a 2-arm robot and thus doubles productivity; an X-module at this location results in a 4-arm robot. In many cases, however, the five or six degrees of freedom are not needed at all. A 3-axis handling arm or a 4-axis pick-and-place configuration can be assembled much more cost-effectively from the same modules. The individual applications and concepts therefore determine the solution.

Beckhoff VCS2000 area scan camera with VOS3000 lens for vision- and AI-based quality control of ring blanks

PC-based control in a ring sawing machine for the watch and jewelry industry

## A vision-based, AI-supported system for shining rings

The mySaw automated ring sawing machine from Carl Benzinger proves that even small systems – which make even smaller end products – can be full of high-tech features. The end-to-end control system from Beckhoff not only provides the high level of system flexibility required in the jewelry sector, but also integrates powerful quality inspection with the seamlessly integrated vision and machine learning solutions.

The watch and jewelry industry places very specific demands on industrial production.



Carl Benzinger GmbH specializes in highly precise, automated CNC turning and milling machines and produces them entirely at its German headquarters in Pforzheim. Lathes for the automotive, precision mechanics, optics, watches and jewelry, and aerospace sectors make up the majority of the machines. Sascha Jentner, Application Technology and Technical Sales Jewelry Machines, explains: “Industrial machines are usually complex and automated to produce specific components. In the jewelry sector, it is more about a particular product, such as a ring, which will be manufactured in an extremely wide range of variants – depending on the ring size and width or material or alloy type. This diversity makes jewelry machines highly individual and sophisticated.”

According to Sascha Jentner, there is currently no machine for ring blanks on the market that is comparable to mySaw: Up to 54 tubes made of materials such as platinum, gold, or silver can be stored as raw material in a tube magazine. A tube that is selected to optimally suit the order in terms of material and offcut is taken from the magazine and the ring is then sawn to the required width, widened to the individual ring size or inner ring circumference and passed on to the next processing machine via an unloading bar. In this way, the entire process of blank preparation is automated, significantly reducing the time and costs involved as well as the loss of material – because very thin saw cuts are made and the resulting chips are collected. The com-

prehensive integration of functions is also confirmed by Christian Spieler, Head of Electrical Design and Software at Carl Benzinger: “Originally, mySaw was designed purely as a sawing machine. The ring widening device was integrated as an addition in order to meet customer requirements as effectively as possible. The implementation of a ring scale as well as AI- and vision-based quality assurance has also made a crucial contribution to the high functionality and efficiency of the system.”

### Numerous movements implemented precisely

The numerous precise motion functions within the sawing machine are crucial for an efficient process flow. First, the rotary indexing tube magazine is moved into the correct position based on the raw material selected for the order. A gripper then removes the tube and guides it past a light barrier – to check the gripper position and dimensions – to the sawing unit, which cuts the ring blank to the desired width. After sawing, the blank falls onto an unloading mandrel and the gripper takes the tube back to the magazine



Control cabinet of the mySaw ring sawing machine with the CX5240 Embedded PC and the connected EtherCAT and TwinSAFE Terminals (top) and the AX8000 multi-axis servo system (bottom)

and removes the next piece of raw material. At the same time, the sawn-off blank is transported to the removal unit either directly or via the integrated ring widening device.

The motion functions for product handling and the sawing unit are implemented via the AX8000 multi-axis servo system and AM8000 servomotors from Beckhoff. In addition, the ring widening device features an AA8033 electric cylinder as a direct drive and an AM8112 servomotor controlled via the EL7211-9014 servomotor EtherCAT Terminal to move a small platform that serves as a ring size target. TwinCAT PLC/NC PTP 10 is used on the software side, installed on the extremely compact CX5240 Embedded PC. Mike Gutekunst, software developer at Carl Benzinger, explains: "All of the engineering is installed on the embedded PC, and very little training and engineering work is required on our part. Another major advantage is TwinCAT's comprehensive simulation capability, which makes it easy to set up a project step by step. This makes our work much easier, especially since TwinCAT Drive Manager 2 allows us to implement all motion systems – from the compact drive technology to the electric cylinder and AX8000 – in a single tool."

Christian Spieler cites further advantages of the Beckhoff drive technology: "We chose the AX8000 multi-axis servo system in particular because of its compact design. Added to this are the advantages of the One Cable Technology (OCT), i.e., space and material savings as well as the electronic nameplate. For example, the different tube magazines can be recognized via the nameplate of the respective servomotor and assigned to the appropriate material database." The project was also made much easier by the EtherCAT industrial Ethernet system with its automatic recognition of all network participants. Furthermore, the openness of EtherCAT makes a wide range of third-party components available and allows them to be easily integrated into the control technology.

### PC-based system openness and IT integration

It is not just EtherCAT which simplifies project implementation due to its openness, but also the PC-based control technology from Beckhoff as a whole. Mike Gutekunst adds: "It is an immense advantage that TwinCAT provides an end-to-end platform in engineering as well as in runtime, right through to visualization with TwinCAT HMI. And since the engineering is also installed on the mySaw target system, it is very easy to access the machine worldwide via remote maintenance and carry out diagnostics or troubleshooting if necessary. For us, however, openness also means the modularity and scalability of TwinCAT, which makes it extremely easy to integrate new functions and machine developments such as the ring widening device. The integration into Visual Studio is another bonus for me as a software developer."

For Christian Spieler, openness is also demonstrated by the ease with which a connection can be established to higher-level IT systems: "This is very important with mySaw, especially with a view to fully automated production. Essentially, there is only a data transmission line to the machine. The end customer orders the ring they want via a configurator and this triggers an order in our customer's ERP or MES system, which is transmitted to mySaw as a data set. Simple IT integration of PC-based control is therefore crucial. With TwinCAT Connectivity, we are also well equipped for future customer requirements such as communication via OPC UA – the keyword here is simple scalability."

### AI and vision seamlessly integrated into control technology

In conjunction with the ring widening device, the mySaw sawing machine also offers AI quality control for the finished ring blanks. Sascha Jentner explains the importance of this: "With the integrated ring widening device, the number of raw material tubes can be minimized despite the extremely high end product variance. Due to the numerous parameters that influence the widening process, such as material properties and quality, ring width and thickness, and the turning of the ring during the process, it is not possible to predict exactly to what extent the ring can be widened or when the material will give way and break. Without AI or machine learning, the machine is therefore unable to determine whether a ring blank is cracked or not – especially as different defect patterns occur depending on the material and because chips or coolant residues can make it more difficult to detect cracks. In the worst-case scenario, a faulty ring goes through the entire machining process in the downstream machine, which would mean unnecessary time and expense."

The most important thing when it comes to successful industrial ring production, however, is ensuring that a faulty product does not reach the end customer, which is why a solution for reliable inline quality control had to be found. Mike Gutekunst explains: "The high functionality and integration of Beckhoff control technology meant that we had various options. First, we checked the extent to which the current consumption of the electric cylinder of the ring widening device could be used for inspections. However, with the seamless integration of machine learning and vision in TwinCAT, we ultimately opted for a final optical inspection. An AI model was developed for this purpose and – supported by Nicolas Camargo Torres from TwinCAT Product Management – it was trained with TwinCAT Machine Learning Creator using only around 200 images of good and bad parts, despite the large number of potential sources of error. Overall, this



Carl Benzinger experts Mike Gutekunst, Software Development, Christian Spieler, Head of Electrical Design and Software, and Sascha Jentner, Application Technology and Technical Sales Jewelry Machines, as well as Benedikt Schwaninger, Beckhoff sales office Pforzheim, (from left to right) behind a mySaw tube magazine

automated training helps us significantly, not least in view of the limited development capacities and the data scientist expertise that would otherwise be required."

TwinCAT Machine Learning Creator supports the development of the AI model with extensive analysis functionality. According to Mike Gutekunst, this is very important in order to identify whether the reliability of the error detection is sufficient for more intensive training or whether something still needs to be adjusted in the upstream process. The trained AI model then runs directly and in real time in the controller with TwinCAT Vision

Neural Network, as easily as any other TwinCAT Function and without expert AI knowledge.

Carl Benzinger also benefits from seamless integration, openness, and scalability with respect to machine vision, which runs on a C6025 ultra-compact Industrial PC – together with the AI extension – for a consistently modular machine design. The PC communicates bidirectionally via ADS with the CX5240 as the machine's main controller through a TwinCAT PLC application for vision and AI and carries out the data transfer and handshake between the two controllers. With TwinCAT Vision, both Beckhoff vision hardware and GigE vision cameras from third-party suppliers can be easily integrated into the control technology. Christian Spieler sees the advantages of the Beckhoff vision solution, with its integrated hardware and software design, as follows: "EtherCAT enables us to integrate the cameras easily and transmit the trigger signals reliably and precisely. The plug-and-play capability, minimized wiring work, and industrial-grade hardware design are all added benefits. In addition, the Beckhoff solution has a very good price/performance ratio overall."

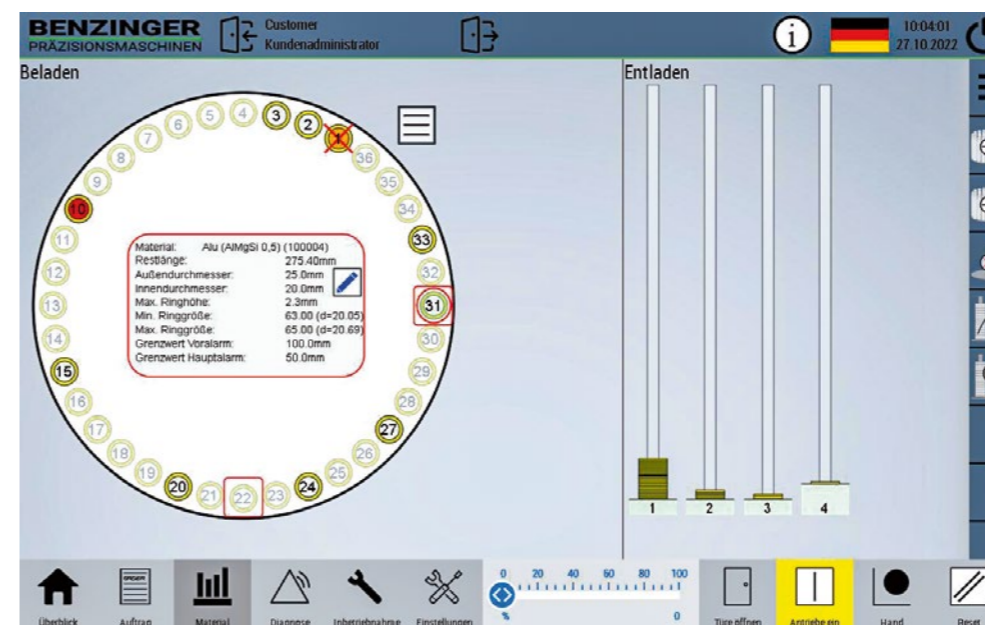

Information on material management in the mySaw user interface created with TwinCAT HMI

More information:

[www.benzinger.de](http://www.benzinger.de)

[www.beckhoff.com/ai](http://www.beckhoff.com/ai)

[www.beckhoff.com/vision](http://www.beckhoff.com/vision)

Upscaling a 5-axis CNC machine with TwinCAT CNC

# Increased working space – same dynamics and precision

It's not just the watchmaking industry that needs compact and dynamic machine tools like the Micro5 from Chiron – in medical technology and mold making, components need to be machined just as precisely and quickly. The workpieces, however, are much larger. The machine builder has therefore scaled up its concept based on PC-based control from Beckhoff for components with an edge length of up to 120 mm.

"Market analyses and discussions have shown that there is indeed a need for a highly dynamic 5-axis CNC machine with a larger milling center than the successful Micro5 series offers for components with an edge length of up to 50 mm," says Matthias Rapp, Vice President Global Marketing at Chiron Group SE in Tuttlingen. Therefore Chiron decided to develop the Micro5 XL building on the existing machine concept, with which Chiron wants to open up further markets that, like in the watchmaking industry, have to produce components with complex geometries and different materials with maximum dynamics, precision, and short cycle times. "Typical target markets for the Micro5 XL include the medical industry and mold making," says Michael Wurster, Senior Product Manager at Chiron.

The AX8000 multi-axis servo system and the C6030 ultra-compact Industrial PC with TwinCAT CNC form the control core of the Micro5 XL 5-axis CNC machine.

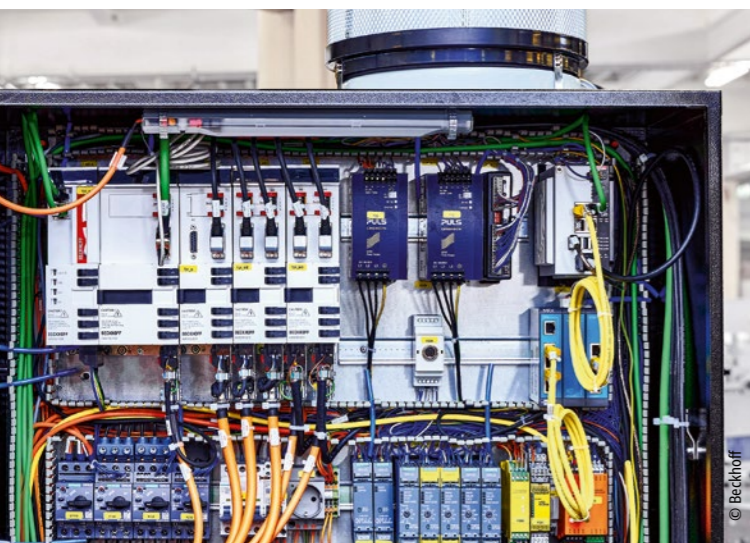

The 5 in the series name stands for what Chiron considers to be the optimum 5:1 ratio of milling center to workpiece size. The XL refers to the enlarged axis structure from 250 mm to 600 mm and the workpiece size of up to 120 mm edge length. "Added to this are higher cutting performance and maximum flexibility," says Mathias Rapp. This is ensured by the tower magazine for up to 100 tools and the optional handling system for loading and unloading. With PC-based control as an open control platform from Beckhoff, the expansions can be mapped in a modular manner in software and hardware.

#### Simple upscaling with a flexible modular drive system

In principle, machine concepts cannot be scaled arbitrarily: At some point the ratio between the moving masses of the workpiece and tool sides diverges. "With the Micro5, we're talking about a moving mass of 10 kg on the tool and workpiece side; with the Micro5 XL, it's up to 80 kg," says Michael Wurster, explaining the challenge of the development project. Nevertheless, Chiron was able to significantly increase the machining area and workpiece size with PC-based control while maintaining the specifications – small footprint and energy requirements with high rigidity and dynamics. "In terms of resource efficiency, we have achieved the optimum with the Micro5 XL, without compromising on precision and speed," says Matthias Rapp with satisfaction.

The wide range of drive components, such as the AX8000 multi-axis servo system, the AM8000 synchronous servomotors, and the compact drive technology in the EtherCAT I/O system, support and facilitate the scaling process. The tower magazine, for example, was implemented with AM8100 servomotors and ELM7212 servomotor EtherCAT Terminals. "These servomotors and EtherCAT Terminals for the low-voltage range up to 48 V DC offer high performance in a very compact design," explains Dieter Völkle. Integrated directly



When scaling the working range of the Micro5 XL to accommodate components with an edge length of up to 120 mm, Chiron was able to draw on the broad portfolio of standard automation components from Beckhoff and use the existing programming for TwinCAT 3 CNC and TwinCAT 3 HMI.

in the EtherCAT terminal segment, they can be used dynamically in the CNC channel or as a PTP axis and synchronized with the other axes.

#### Small footprint through compact control technology

With a footprint of just 1.7 m<sup>2</sup> for the complete machine tool including peripherals (coolant system and chip management), space for the control technology is tight. Chiron gains valuable space with One Cable Technology (OCT) as its connection technology, among other things. Michael Wurster comments: "Together with the AX8000 multi-axis servo system and the servomotor EtherCAT Terminals, this has simplified the compact set-up and also saved time during installation." And if a motor cable ever needs to be replaced, OCT makes this much quicker than laying two separate cables for the motor and feedback system.

As the Micro5 XL was developed with great attention to balanced mass ratios, the up-scaling had no negative effects on the control behavior. "We were able to use the TwinCAT 3 Motion Designer project planning tools to design the drive axes and controllers, and received excellent support from the Beckhoff experts for fine-tuning based on the Bode diagrams and the load spectra we specified," confirms Michael Wurster.

Dieter Völkle (Sales, Beckhoff branch in Balingen) with Tobias Widinger, Micro5 XL System Engineer, Senior Product Manager Michael Wurster, and Development Engineer Jan Steppacher (all Chiron Group SE) in front of the 5-axis CNC (from left to right).

#### Faster, more precise, and a finer finish

In the end, Chiron was able to achieve further improvements in machining with the Micro5 XL in terms of cycle times, surface quality, and dimensional accuracy compared to standard machines on the market for machining this component cubature. "This is partly due to the even mass distribution between the tool and the workpiece side and, of course, also to precise control with TwinCAT 3 CNC," says Matthias Rapp. Dieter Völkle outlines another important aspect for series machine manufacturers such as Chiron: "In the long term, it is an advantage not to need any special solutions and to be able to implement everything with standard components."

Chiron uses a C6030 ultra-compact Industrial PC as the control platform for the 5-axis CNC machine, on which TwinCAT 3 CNC (TC1270) with numerous technical functions such as TwinCAT 3 CNC Spline Interpolation (TF5260), CNC Channel Pack (TF5230), CNC High-Speed-Cutting (TF1250), CNC Axes Pack (TC5220), and CNC Transformation (TF5240) are installed. The movements of the five axes and the screw are interpolated and synchronized via one channel of the software CNC; the servo drives of the tool changer are synchronized via the second channel. The user interface of the Micro5 XL is based on TwinCAT 3 HMI (TF2000) and

Matthias Rapp,

Vice President Global Marketing at Chiron Group SE

“In terms of resource efficiency, we have achieved the optimum with the Micro5 XL, without compromising on precision and speed.”

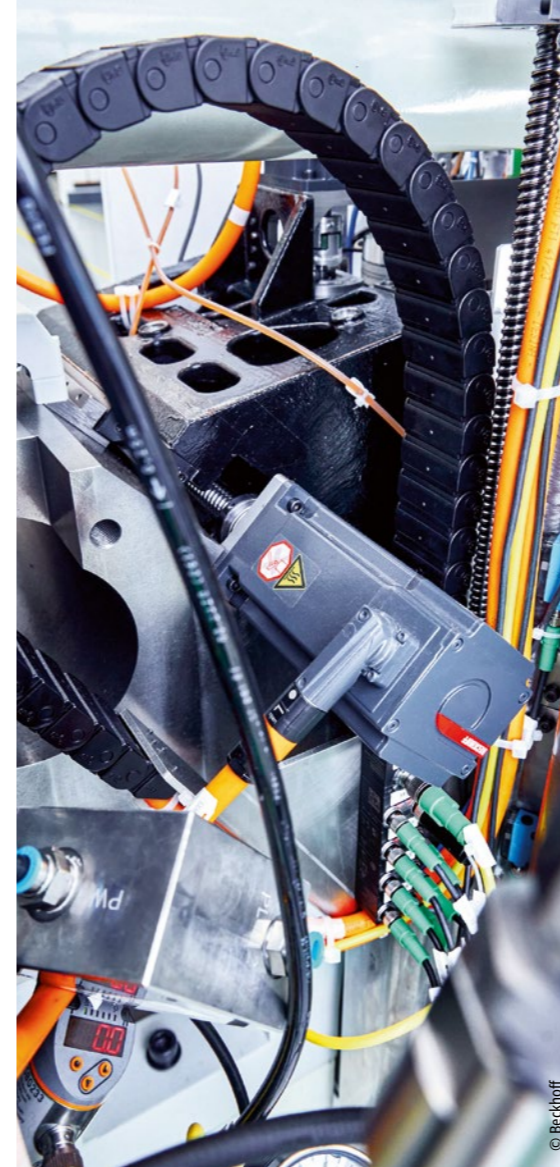

The One Cable Technology (OCT) connection technology for the AM8000 and AM8100 servomotors saves installation time and space.

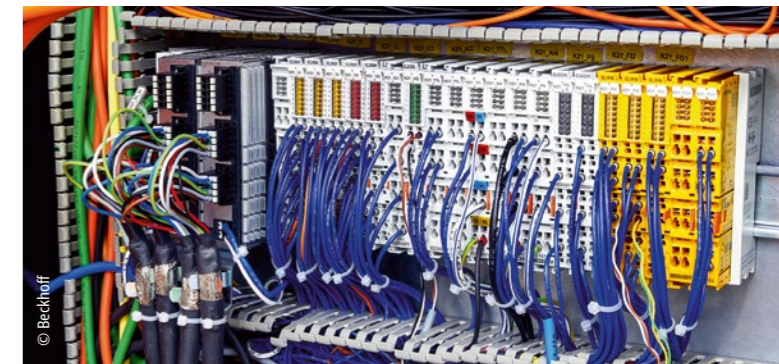

The ELM7212 2-channel servomotor EtherCAT Terminals for controlling the AM8100 servomotors of the tower magazine can be integrated into any EtherCAT Terminal segment to save space.

the CNC visualization for machine tools programmed in C#. "We keep hearing from customers how easy it is to use our machine tools with TwinCAT HMI from Beckhoff," says Matthias Rapp. "A Swiss watch designer taught herself how to program and mills her designs herself using a Micro5."

#### Documenting efficient production

Chiron uses TwinCAT 3 Analytics Logger (TF3500) to control the machining process. "We want to use the drive currents to determine the cutting forces and thus protect the screw from overload," says Michael Wurster. In addition, a vibration sensor monitors the machine tool. Chiron records the current consumption via an EL34xx EtherCAT power measurement terminal and displays the current energy requirement to the operator in the visualization. "Compared to other machines on which similar parts are manufactured, we achieve energy savings of around 50% and can also prove this with the energy measurement solution from Beckhoff," says Matthias Rapp, highlighting an important aspect. If users want to calculate the carbon footprint of their products, they can assign the consumption values to a specific production batch. As various industrialized countries promote efficiency measures in production, this function can be decisive for customer wins. Many companies have also set up their own efficiency programs that go beyond the legal requirements and require suppliers to provide information on energy consumption or carbon emission per component. "With the power measurement technology from Beckhoff, this can be easily implemented and transferred to energy management systems or MES via OPC UA," says Dieter Völkle.

Chiron has a wide range of different machine tools and machining centers in its portfolio. "We will be looking step by step at the various options that PC-based control from Beckhoff opens up for us," adds Matthias Rapp.

The tool changer is controlled by AM8100 servomotors via the second TwinCAT CNC channel.

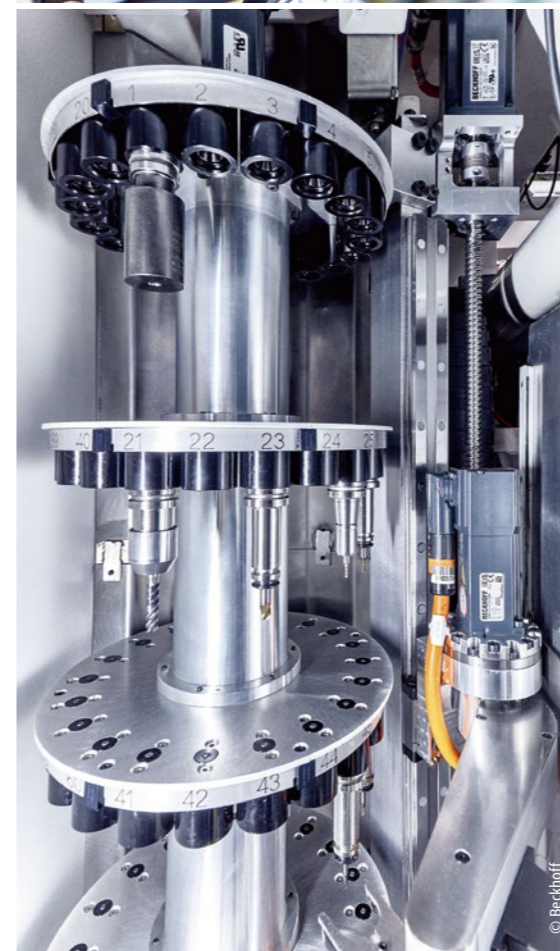

More information:

[www.chiron-group.com](http://www.chiron-group.com)

[www.beckhoff.com/machine-tools](http://www.beckhoff.com/machine-tools)

Comprehensive retrofit of a tufting machine for carpet production

# Computing power and integrated stepper motor drives increase quality and availability



A C6032 ultra-compact Industrial PC with eight CPU cores controls the entire system; in order to maintain the required cycle time of 1 ms, the drives and the I/O level were integrated via a total of five EtherCAT segments.

During the retrofit of the tufting machine, all of the control and drive technology was exchanged and the previous yarn feed roller was replaced with 424 compact ASI8114 stepper motor drives with integrated output stage.

When the electronics started to fail more and more often, Vetex – based in Herzebrock – realized it was time to retrofit one of its tufting machines and migrate to PC-based control. The compact drive technology from Beckhoff enabled a new type of yarn infeed: 424 integrated ASI8114 stepper motor drives replace the usual yarn feed rollers and feed the system with around 1,700 yarn threads – complete with individual and very fast control of the thread length and monitoring of the thread tension.

Herzebrock-based carpet specialist Vetex offers carpets in a wide variety of patterns, colors, and dimensions. The spectrum of products marketed worldwide under the Inffloor-Girloom brand is large and encompasses standard commercial products in several quality levels from 500 g/m<sup>2</sup> to over 2,000 g/m<sup>2</sup> pile weight. “Other highlights include carpets with individually printed motifs and our self-adhesive carpet tiles, which can be laid directly on dust-free, smooth subfloors and removed again at any time without leaving any residue,” says Josef Röttgers, Head of Production and Product Management at Vetex.

The most commonly used process for carpets worldwide is tufting, a technique between sewing and embroidery. Needles threaded with the pile yarn (tufting yarn) pierce the backing material, which is moved synchronously to the machine cycle by a feed roller and a take-off roller. The vertical needles are arranged across the entire width of the tufting machine – in the case of the Vetex machine, exactly 1,696 needles across a width of 4.29 meters. “That corresponds to ten needles per inch of carpet width,” explains Ralf Bosch, production manager for the Vetex tufting and weaving division. Grippers form the

pile thread loops on the back of the pierced backing layer and fix their height. If these grippers are also equipped with blades, the loops can be cut open so that the pile loop fabric becomes a velour carpet.

For Infloor-Girloon's target markets – hotel chains, offices, insurance companies, specialist retailers, and the construction industry – quality and durability are extremely important, as is the ability to create customized carpet designs with regard to coloring, texture, and pattern. "It is essential that the production process is as smooth and precise as possible, which was no longer

Top: The thread tension is displayed synchronously to the cycle via the torque of the stepper motor drives in the visualization created with TwinCAT 3 PLC HMI; each dot in the matrix above the thread infeed represents one of the 424 stepper motor drives.

Bottom: The compact ASI8114 stepper motor drives (flange dimension 42 mm) and their space-saving connection technology with around 1,000 pre-assembled cables were what made it possible to achieve individual infeed and control of the 1,696 yarn threads.



© Beckhoff



© Beckhoff

possible with the previous control technology," says Ralf Bosch, emphasizing the necessity of the retrofit implemented by Beckhoff and machine builder Gierecker & Brökelmann in Rheda-Wiedenbrück. For this reason, the tufting machine's electronics, which had become increasingly susceptible to faults, were completely replaced with powerful and flexible control and drive technology – PC-based control. "We have been using PC-based control technology from Beckhoff for about seven years and are modernizing our machines with it step by step," says Josef Röttgers.

#### Yarn feed with over 400 compact stepper motor drives

During the retrofit of the tufting machine, the previous drive technology was replaced with various AM8000 synchronous servomotors and AX5000 compact servo drives, which control aspects such as the needle stroke, the feed of the tufting fabric, the press foot, and the lifting table. "For the most important part of the retrofit – the precise yarn feed and thread tension – Vetex relies on a new concept that could only be implemented in this form with the compact integrated ASI8114 stepper motor drives," explains Jens Hülsebusch, project manager and programmer of the retrofit at Beckhoff. A total of 424 stepper motors with integrated amplifiers each pull four threads from the creel via corresponding shafts and make them available to the machine via scramble box and puller rolls. The speeds of the yarn drives can change up to ten times per second.

"Due to their compact dimensions, the flange dimension of 42 mm, and the low power consumption, the stepper motor drives could be mounted very closely," adds Christian Mische, Senior Product Manager Drive Technology at Beckhoff. "Compared to other solutions, the design effort required for the infeed of the 1,696 individual yarns is therefore much lower and more precise," confirms Ralf Bosch.

The compact drive technology with 48 V DC supply voltage saves valuable installation space – but that's not all. Its internal feedback system turns the stepper motors into a precise servo drive with field-oriented control. Compared to traditional stepper motors, this means that energy consumption and heat generation are much lower, reducing the power consumption from just under 8 kW for a conventional machine to around 4 kW after the retrofit. "With 2-shift operation and several machines, this is definitely noticeable in terms of energy consumption and the CO<sub>2</sub> balance," says Ralf Bosch. The necessary power for the stepper motor drives is provided by 19 PS3000 power supplies.

PC-based control regulates the thread tension via the motor current or the resulting torque and detects whether the tension is too high or a thread is broken. "Both have a direct effect on the quality of the carpet," says Josef Röttgers. The thread tensions are displayed to the machine operator on the CP2918 Control Panel via a dot matrix. "The operator can immediately see from the colors where the thread infeed is hooked and can intervene if necessary," says Jens Hülsebusch. To ensure that this display works synchronously with the machine cycle, the visualization was created with the TwinCAT 3 PLC HMI (TF1800).

#### Eight processor cores for short cycle times

TwinCAT calculates the motor current or torque for the required thread tension with a cycle time of 1 ms. "To ensure this short cycle, the many stepper motors and other tasks were divided between the eight CPU cores of the C6032 ultra-compact Industrial PC and several EtherCAT segments," explains



The project experts (from left to right): Jens Hülsebusch (Beckhoff systems engineering), Ralf Bosch and Josef Röttgers (both Vetex) with Tim-Louis Rütger and Christian Mische (both Beckhoff) between the creel (right) and the tufting machine modernized with PC-based control.

Jens Hülsebusch. One Ethernet interface connects 100 of the stepper motor drives to the industrial PC in each case. A fifth junction connects the remaining EtherCAT Terminals and EP box modules as well as the AX5000 compact servo drives for the other drives of the tufting machine. The NC part, the visualization, and the slow and fast processes are each assigned to a further CPU core. "In this application, we make full use of the flexibility of PC-based control and the performance of the industrial PC," says Jens Hülsebusch.

Josef Röttgers confirms this: "The retrofit of the machine was the most complicated conversion at Vetex to date, but thanks to the excellent preparation and expertise of Beckhoff systems engineering, it went off without a hitch." Some of the challenges included the individual control of the many drives depending on the carpet design, and the interpretation and handling of the bitmap of a pattern in the control system. "The individual patterns are created when the threads are stitched through the base fabric at different lengths," says Ralf Bosch. To do this, TwinCAT must translate the pattern planned by a graphic designer pixel by pixel into position setpoints and yarn lengths for each of the 424 stepper motor drives and generate the motion profiles. PC-based control can make full use of its strengths here, as the C6032 ultra-compact Industrial

PC – in conjunction with TwinCAT 3 – provides sufficient real-time memory to read and process the approximately 10 MB files. The connection between the controller and the design department or order planning is established via TwinCAT 3 XML Server (TF6421). The demanding motion sequences were implemented with TwinCAT 3 PLC/NC PTP (TC1250) and NC Camming (TF5050).

Josef Röttgers, Vetex

“The retrofit of the machine was the most complicated conversion at Vetex to date, but thanks to the excellent preparation and expertise of Beckhoff systems engineering, it went off without a hitch.”

Following the extremely positive experience, Vetex is getting ready for further modernizations: In addition to the conversion of a cutting system for the self-adhesive carpet tiles, Josef Röttgers is already planning the retrofit of another tufting machine for next year.

More information:

[www.infloor-girloon.de/en](http://www.infloor-girloon.de/en)

[www.gierecker-broekelmann.de](http://www.gierecker-broekelmann.de)

[www.beckhoff.com/asi8100](http://www.beckhoff.com/asi8100)

PC-based control for solar fuel synthesis on an industrial scale

# Reliable production of ecofuels from solar energy with PC-based process control technology

The flexible topology options of EtherCAT in connection with the EK1122 2-port EtherCAT junctions and the EK1521 1-port EtherCAT fiber optic junctions (right) facilitate the connection of 1,000 sensors and actuators distributed over six levels.



In the DAWN industrial test facility, Synhelion produces sustainable fuel from solar energy using PC-based control as a process control system.

Switzerland's Synhelion AG produces sustainable, synthetic fuels using solar energy. In summer 2024, the first industrial demonstration plant, DAWN, was put into operation in Jülich. Automated and monitored with PC-based control from Beckhoff as the process control technology, this represents an important milestone on the way to a large-scale industrial plant.

In the DAWN industrial demonstration plant, Synhelion uses the "sun-to-liquid" process with concentrated solar thermal energy (CST) for the production of solar fuels. The plant consists of four central components: the heliostats (mirrors), the receiver with 600 kW thermal output, the thermochemical reactor, and the thermal energy storage unit.

Over 200 heliostats focus the solar radiation onto the receiver, i.e., a combustion chamber at the top of the tower in which a heat transfer medium is heated to over 1,500°C for a sustained period. The process heat generated in this way is fed into a thermochemical reactor, which produces a synthesis gas from a RED-certified carbon source ( $\text{CO}_2 + \text{CH}_4$ ) and water. This gas is then turned into fuels using industrial processes. "Our focus is on kerosene, diesel, and gasoline so we can supply the transportation sector with sustainable fuels," says Adrian González, Head Engineer for Process Automation at Synhelion. The advantage of these fuels is that the existing infrastructure (tank farms, transporters, dispensers) can continue to be used. Instead of the usual kerosene, one of the tanks will contain the ecofuel in this case to be added in accordance with the regulations. "This is much easier and more efficient than converting a fleet of aircraft to hydrogen," says Adrian González.

The excess energy from the receiver is fed into a thermal energy storage unit developed by Synhelion and can be fed back into the process at any time. "The ceramic storage tank for the process heat extends over two levels of the solar tower," says Adrian González, explaining the dimensions of the plant, "and also fulfills an important function – ensuring continuous operation independent of solar radiation." Instead of the heliostats, an electric heating system can also be used, which draws its energy from photovoltaic systems or wind turbines, for example. "This is particularly relevant when there is an oversupply of renewable energy in the distribution grid," says Jesse Schneider, the programmer responsible for the plant, explaining the flexible approach to energy supply.

## Synthetic crude oil requires sophisticated control technology

Since fall 2024, the Synhelion plant has been producing synthetic crude oil (syncrude) which is almost identical to its fossil counterpart. The entire manufacturing process is controlled and monitored by around 1,000 sensors and actuators networked via EtherCAT, with TwinCAT as the process control system and a C6030 ultra-compact Industrial PC. "Despite the many sensors and even more data points, the cycle time of the TwinCAT runtime remains

well below 10 ms and gives us more than enough flexibility for tests and expansions,” says Adrian González. The plant in Jülich is the industrial-scale test system which Synhelion is using to test, validate, and optimize the process control of various end products on even larger plants. As a result, the process control technology needs to be flexible and easy to expand. “With PC-based control and the scalable hardware, the control technology and I/O level can be adapted very flexibly to actual requirements and additional measuring points can be retrofitted at any time,” adds Wilm Schadach, Branch Manager at Beckhoff Monheim.

Although the process does not place any extreme demands on performance, the large number of different sensors and actuators alone was seen as critical at the beginning of the planning phase. “The comprehensive range of EtherCAT Terminals and the flexible topology options of EtherCAT really helped us to collect the I/Os that are distributed over four levels, integrate them into the controller, and map them in the HMI,” says Iesse Schneider. The ability to integrate the sensors and actuators in hazardous areas (ATEX) directly into the EtherCAT communication via ELX terminals was also a great advantage. “Numerous EtherCAT Terminals from the ELX series are used in the project,” adds Sebastian Böse, who works in process industry management at Beckhoff. Almost 600 terminals were installed in total, spread over 27 control cabinets on six levels. The 37 different terminal types include various EtherCAT Terminals with communication interfaces for Modbus TCP, Profinet®, and HART.

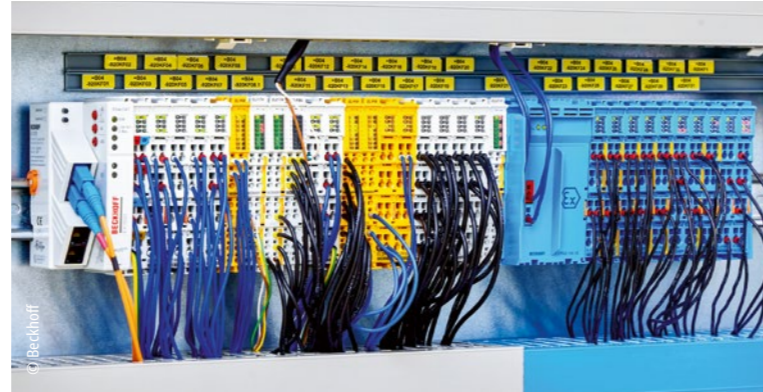

In addition to EtherCAT Terminals for process signals from Zone 2 hazardous areas, safety-related functions are implemented with the EL1918 and EL2912 TwinSAFE Terminals as well as EL3174, EL3214, and ELX3152-0090 TwinSAFE SC Terminals.

There are also numerous safety functions that have been implemented using TwinSAFE SC and TwinSAFE Terminals. “In total, around 40 functions – some of which are SIL2-rated – were implemented on the basis of IEC 61511,” says Iesse Schneider. EtherCAT and Safety over EtherCAT (FSoE) play an important role here. The initial approach was to use one EL1918 TwinSAFE Terminal with TwinSAFE Logic as the safety controller. However, as it was not possible to map all of the plant’s safety functions with the terminal’s maximum of 512 function

blocks, the function blocks – numbering more than 700 in total – were distributed across four EL1918s. These receive the information from the sensors and actuators via FSoE and communicate with each other.

#### Reliable data logging with open control

In parallel with process control, data logging takes place via EtherCAT at different intervals. “This can be conveniently configured for each data point in TwinCAT and the data can be saved. EtherCAT also gives each process value a precise timestamp,” says Sebastian Böse. Intelligent logging strategies ensure that the data is only saved if the process value changes, for example. In total, the plant has around 50,000 data points, which TwinCAT provides via an OPC UA server. “The openness of PC-based control and OPC UA is also an advantage here,” adds Adrian González. It enabled Synhelion to install a third-party data logger on the C6030 ultra-compact Industrial PC, which retrieves the data on site. This has the advantage that if the communication connection fails, the data is always recorded and is not lost. “For test facilities, this is extremely important,” says Adrian González.

EtherCAT’s wide range of diagnostic options also made the work easier and quickly uncovered the typical errors that occur during commissioning of large plants of this kind. Using the extensive diagnostics, Synhelion was able to quickly rule out communication errors and concentrate on the configuration of the devices. “EtherCAT is a backbone that you can rely on,” says Wilm Schadach.

TwinCAT HMI Server (TF2000) communicates with the industrial PC via ADS and displays the information in the control room on a main workstation, four small monitors, and a large process overview monitor. If required, additional monitors can be added for data visualization. The TwinCAT HMI is a perfect platform for complete plant control and goes far beyond simple HMI solutions. In future, the process library will facilitate tasks that would otherwise have to be performed by a separate SCADA system.

Scaling is facilitated by technologies such as MTP and NOA, which allow the process control technology of individual modules to be flexibly integrated into existing plant structures. Sebastian Böse comments: “Beckhoff already provides a large selection of HMI and PLC function blocks for the development of MTP-compliant modules. In addition, the amount of development work required is reduced significantly by means of automatic code generation.” With a view to future projects, MTP is a very exciting prospect for Adrian González: “In the medium term, we see ourselves as a company that licenses its technology and makes it available to other fuel suppliers. A general contractor can then add Synhelion’s modules to its plant and integrate automation into its control technology using MTP and NOA based on our P&ID diagrams and controls.”



Left: The receiver with 600 kW thermal output and the ceramic energy storage unit (in the foreground) are monitored via numerous thermocouples.

Right: Adrian González, Felix Zimmermann, and Iesse Schneider (all Synhelion) with Sebastian Böse and Wilm Schadach (both Beckhoff) in front of the receiver on level four of the solar tower (from right to left)

More information:

[www.synhelion.com](http://www.synhelion.com)

[www.beckhoff.com/processindustry](http://www.beckhoff.com/processindustry)

[www.beckhoff.com/twinsafe](http://www.beckhoff.com/twinsafe)



The 18-km long Fehmarnbelt tunnel between Rødbyhavn on Lolland in Denmark and Puttgarden on the German island of Fehmarn will be the world's longest immersed tunnel by 2029. To this end, 79 standard tunnel elements with a length of around 220 m and a further ten special elements are being manufactured on a 150-hectare construction site near Rødbyhavn. Swiss companies Hebetec Engineering AG and Elpex AG are automating and controlling the safe transport of the elements, which weigh over 73,000 tons, using EtherCAT terminals and PC-based control technology from Beckhoff.

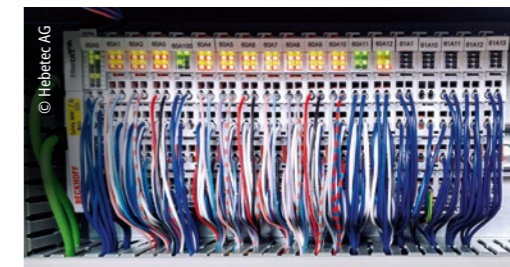

Distributed across more than 100 control cabinets, over 1,000 EtherCAT Terminals record the forces and pressures on the presses, accumulators, and hydraulic units.

EtherCAT-based control technology for transporting gigantic tunnel elements

# In use on Northern Europe's largest construction site

By 2029, the world's longest immersed tunnel will be built between Germany and Denmark with PC-based control from Beckhoff.



A total of 79 gigantic standard tunnel elements are being concreted on five lines in Rødbyhavn on Lolland in Denmark. Each element is around 220 m long and 43 m wide and weighs over 73,000 tons.



Benjamin Schwab, software team leader, Urs Krähenbühl, deputy managing director (both Elpex), and Andreas Iseli, head of the Beckhoff office in Lyssach (from left to right)

The Fehmarnbelt tunnel is being built using the same technology that was used for the Øresund connection between Denmark and Sweden: immersed tunnels. The tunnel requires 79 standard and 10 special elements for installing the tunnel infrastructure. To start an element, reinforcing steel is connected to form a cage and pushed into prepared formwork. Concrete pouring then begins in the casting hall. Once the concrete has hardened sufficiently, the formwork is partially removed and the first 24-m long segment is moved to make room for the next reinforcement cage.

This process is repeated until all nine segments of a tunnel element have been concreted and successively pushed out of the hall into the dry dock. There, the 217-m long tunnel elements are sealed with bulkheads. Despite weighing around 73,500 tons, the components float when the dock is flooded and can be pulled into the harbor basin. In order to meet the tight schedule for completion in 2029, the standard elements are being concreted on five parallel lines.

### Moving gigantic masses precisely and quickly

Throughout the entire process, the huge tunnel segments are leveled on hydraulic supports and pushed several hundred meters using hydraulic rams. The concept was developed by Swiss company Hebetec AG in Hindelbank and automated in collaboration with Beckhoff Solution Provider Elpex AG in Kirchberg. "Moving the 43-m wide elements, which were over 200 m long in the end, safely and precisely from the concrete hall to the basin was a real challenge," emphasizes Olivier Briguet, Head of Operations at Hebetec. Each line is fed by six double hydraulic cylinders with a stroke of 1.8 m, which are mounted on a movable frame that is pressed against the side of the skidding beams by means of jaws. The six rams press the segments evenly forward, then release their clamping, retract, and are pulled forward in the process. Then the process starts all over again.



Six of these pushers, each with two cylinders, push the tunnel segments evenly over several hundred meters through a narrow gate into the dry dock during continuous production.

"The skidding beams are around 400 m long and of course not perfectly straight," Olivier Briguet points out a further complication. To avoid stresses in the concrete, the segments are continuously leveled using dozens of lifting cylinders. For the leveling of one segment alone, 36 presses – divided into three hydraulic groups – have to be controlled. This compensates for the tolerance of +/-5 mm and minimizes friction due to the smaller contact surface. "The force required for pushing is significantly lower at 1.2% of the hydraulic power than the initially calculated 5%. This saves Femern Link Contractors, the manufacturer of the tunnel elements, a lot of energy costs," says Urs Krähenbühl, deputy managing director at Elpex.

Furthermore, the weight of the segments is not homogeneous. This must be taken into account when pushing to prevent the tunnel elements from tilting – as must the different friction on the lifting cylinders. The tunnel segment will only stay on track if all pushers (presses) push with the same force. "To do this, we use pressure sensors on each leveling ram to record the weight and use TwinCAT to control the pressing force of the pushers via the speed of the hydraulic pumps," explains Benjamin Schwab, software team leader at Elpex. In addition, the operator riding along on the segment in the control cabin can intervene and individually adjust the pressure of individual feed cylinders via an overflow valve. To assist the operator, there is a guidance system that detects and displays the direction. At the end of the construction hall, the 43-m wide segments have to pass through a relatively narrow gate in as straight an orientation as possible.

### Control and monitoring station are riding along

The project involves the use of a large number of presses with a force of 240 to 390 tons and hydraulic accumulators to meet the operator's requirements for continuous production of the segments at a rate of 10 m/h. Feed, leveling, and direction are monitored and controlled by the operator using a

CP2924 multi-touch Control Panel. The control station is located in a small container, which is placed on the tunnel segment together with the accumulators and moved along with it.

In line with the size of the project, the quantity structure of the control technology is also extremely extensive: Distributed across a large number of control cabinets with a total connected load of 820 kW, a large number of analog EtherCAT Terminals (EL3024) and digital input/output terminals are installed for recording all signals and precisely controlling the motors and hydraulic valves. There is also a wide range of power supply terminals and EK1914 EtherCAT Couplers with integrated standard and safety I/Os as well as EL6910 EtherCAT Terminals with TwinSAFE Logic. C6030 ultra-compact Industrial PCs are used for control purposes. "As a rough estimate, we laid around 4.5 km of cable for the power supply, 3.5 km of EtherCAT cables, and 67 km of control cables," says Urs Krähenbühl, outlining the scope of the project. "The flexible topology selection options offered by EtherCAT were a great help when it came to cabling," adds Benjamin Schwab, software team leader at Elpex. This allowed the accumulators distributed across the tunnel segments to be connected in line, while the pushers on a production line were connected using a CU1128 8-port EtherCAT junction in a star topology.

### Flexibility provided by EtherCAT and hot connect

"We have laid everything out twice for each production line because we have to start on the next tunnel element while the other one is still leaving the hall," says Olivier Briguet. It must also be possible to replace defective components quickly and easily. "The EtherCAT hot connect function gives Hebetec and Elpex the flexibility they need," confirms Andreas Iseli, head of the Beckhoff office in Lyssach. To this end, Elpex configured the many different combinations of cylinders and accumulators. This enables the fitters to take the required components from the warehouse to start a new segment or in the event of a defect, mount them on the line and connect them using connectors.

### Safety project implemented with EAP and cross traffic

"Given that devices aren't permanently installed and can be connected in almost any combination, we also needed a universal solution for the safety application," says Benjamin Schwab, pointing out a special feature: A typical



TwinCAT and C6030 ultra-compact Industrial PCs are used to control the many presses for precise leveling, uniform feed, and exact alignment of the tunnel elements.

safety control always requires clearly specified configurations. In this project, the safety control must automatically detect the respective combination of devices during startup and compare it with the configuration set on the HMI. "With hot connect, we were able to achieve this flexibility in the safety section as well," says Benjamin Schwab. However, due to the large number of device combinations, more TwinSAFE groups had to be configured than those supported by an EL6910 EtherCAT Terminal. Elpex was able to implement this easily with a second EL6910, which communicates with the other TwinSAFE Terminal via the EtherCAT Automation Protocol (EAP). "Hans Baumberger, application engineer at Beckhoff, provided us with a great deal of support during the implementation of cross-communication," recalls Benjamin Schwab.

Despite the extensive quantity structure, Elpex only needed 1,800 hours for engineering and programming with TwinCAT. EtherCAT was also very helpful in configuring, testing, and commissioning the extremely large number of hydraulic valves and other components, enabling the plant to be commissioned in around 300 hours. "PC-based control and Beckhoff were the perfect technology and the ideal partner for this unique project," concludes Urs Krähenbühl.

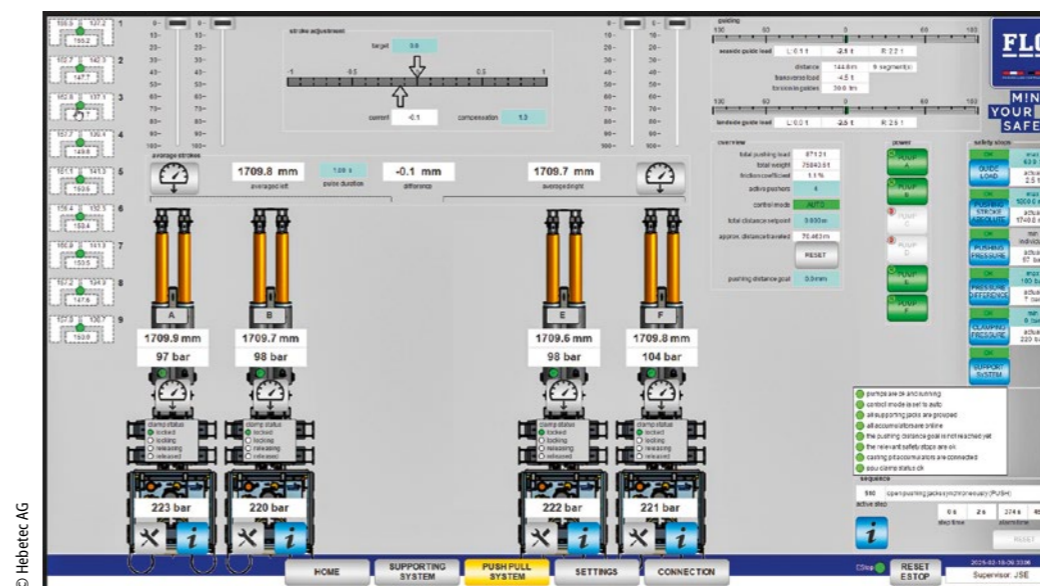

The operator monitors and controls the feed, leveling, and alignment of the tunnel segments using the visualization implemented with TwinCAT HMI.

More information:  
[www.hebetec.com](http://www.hebetec.com)  
[www.elpex.ch](http://www.elpex.ch)  
[www.femern.com](http://www.femern.com)  
[www.beckhoff.com/ethercat](http://www.beckhoff.com/ethercat)

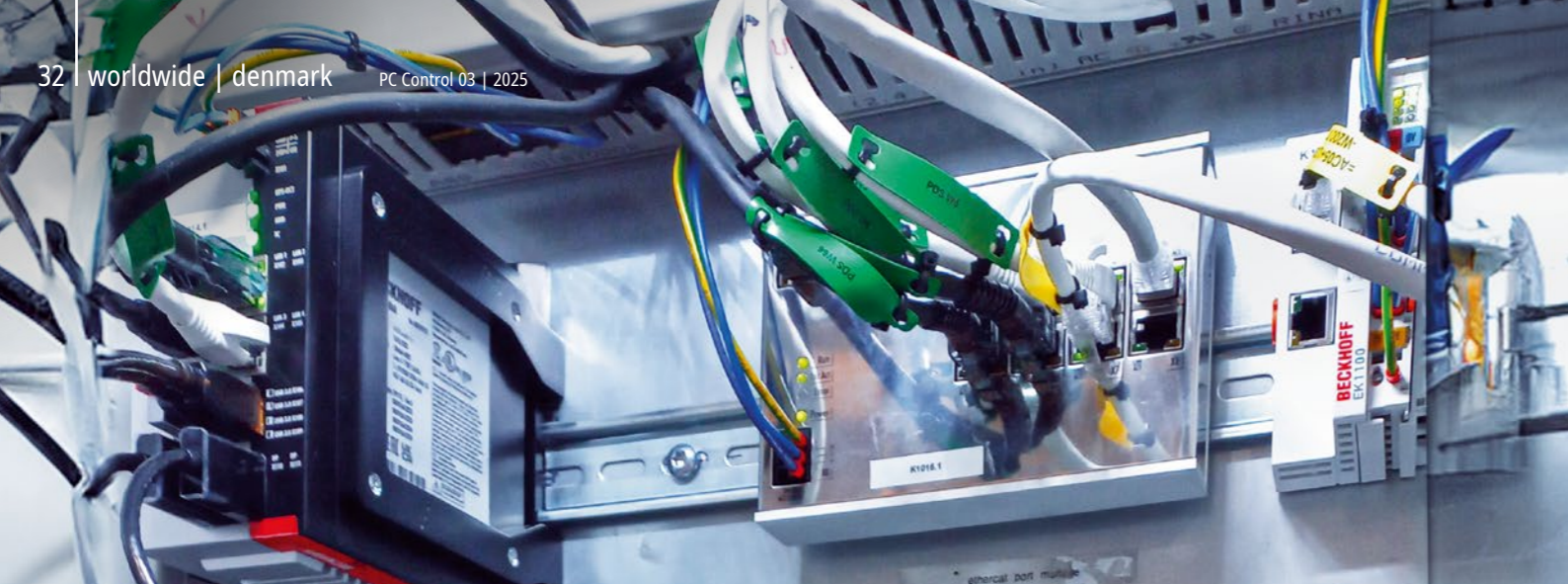

Automated converter testing for next-generation wind turbines

## Modern testing technology for the transformation of Europe's energy grid



Beckhoff computers in use: a C6030 ultra-compact Industrial PC (top left) and two CX2043 Embedded PCs (center and bottom)

As the prevalence of renewable power generation increases, Europe's electricity grid is undergoing a fundamental transformation – particularly due to the increasing use of converter systems that are coupled to the grid via power electronics. This results in new requirements for modern test rigs, which Siemens Gamesa Renewable Energy A/S (SGRE) has implemented with the Grid-Converter Test Rig (G-CTR) using PC- and EtherCAT-based Beckhoff control technology.

Modern power electronics enable extensive controllability for grid support. Compared to conventional synchronous generators, however, they are less able to provide short-circuit current, which limits the support for the grid in the event of a fault. With regard to system stability, controlling the interactions between generation units in terms of subsynchronous and harmonic stability at system level is also becoming increasingly important.

Against this backdrop, wind turbine manufacturers are conducting test campaigns on prototypes to determine grid characteristics and create validated models of electrical behavior that are required for further analysis at system level. Conventional testing and validation procedures for wind turbines are technically mature and have been successfully applied in field operation for many years. However, the growing challenges of modern power grids require complementary approaches to extend the scope of validation beyond traditional methods. For this reason, Siemens Gamesa employs innovative methods for validation on modern test rigs in addition to the existing field tests. Programmable grid emulator systems are used in combination with many years of field experience to expand the scope of validation in a targeted and efficient manner.

### Modern test rigs extend the scope of validation

The Grid-Converter Test Rig is a test rig for flexible and reproducible testing of the wind turbine converter system, a key component that has a significant influence on grid properties. Testing and validation in the field is carried out under real conditions on the entire generation unit. However, since the grid conditions there can only be changed to a limited extent, a programmable grid emulator on the test rig offers extended validation potential – both for static and transient grid characteristics and for harmonic behavior. Due to the adjustable supply voltage on the test rig, flexible operation is possible across the entire operating range in terms of voltage, active power, and reactive power. This makes it possible to validate the grid-serving performance of the wind turbine converter system on the basis of measurements, which is not

possible in this form under field conditions. In addition, the adjustability of the grid short-circuit power as well as of the X/R ratio enables the realistic simulation of field-specific grid scenarios for offshore wind farms – both in normal operation and in the event of a fault. The targeted injection of voltage harmonics also makes it possible to determine the frequency-dependent impedance behavior, which forms the basis for validating harmonic models of the entire electrical system.

The use of EtherCAT and PC-based control technology from Beckhoff creates a high-performance and flexible test environment that can precisely map even highly complex and dynamic scenarios.



The G-CTR Power Hardware-in-the-Loop (PHIL) test rig was built by SGRE in Brande, Denmark. Siemens Gamesa relies on PC-based control and support from Beckhoff to meet the high requirements regarding automation, fast and dynamic control, and the acquisition and recording of high-frequency signals, voltages, and currents.

In the G-CTR, the converter being tested – the device under test (DUT) – is positioned between two grid emulators. These ABB ACS6080 medium-voltage converters offer advantages for PHIL

due to their precise emulation of grid conditions and high flexibility. The converters are used to carry out realistic tests and certifications of energy sources such as wind turbines by simulating various grid scenarios and fault conditions. One medium-voltage converter emulates the grid on one side and the other converter emulates the generator on the other. The grid emulators can set three-phase voltages and currents highly dynamically, generate grid faults, and emulate impedances and harmonics.

These grid emulators are connected via EtherCAT to the higher-level test controller, which defines the test scenarios and monitors the system, including other subsystems such as the cooling and safety system. This involves using a C6030 ultra-compact Industrial PC from Beckhoff, which combines the numerous EtherCAT networks via a CU2508 real-time Ethernet port multiplier.

Two Beckhoff CX2043 Embedded PCs also enable highly dynamic control of the grid and generator emulators via the EL6695 EtherCAT bridge terminal and integrate simulation models for HiL test procedures, among other things.

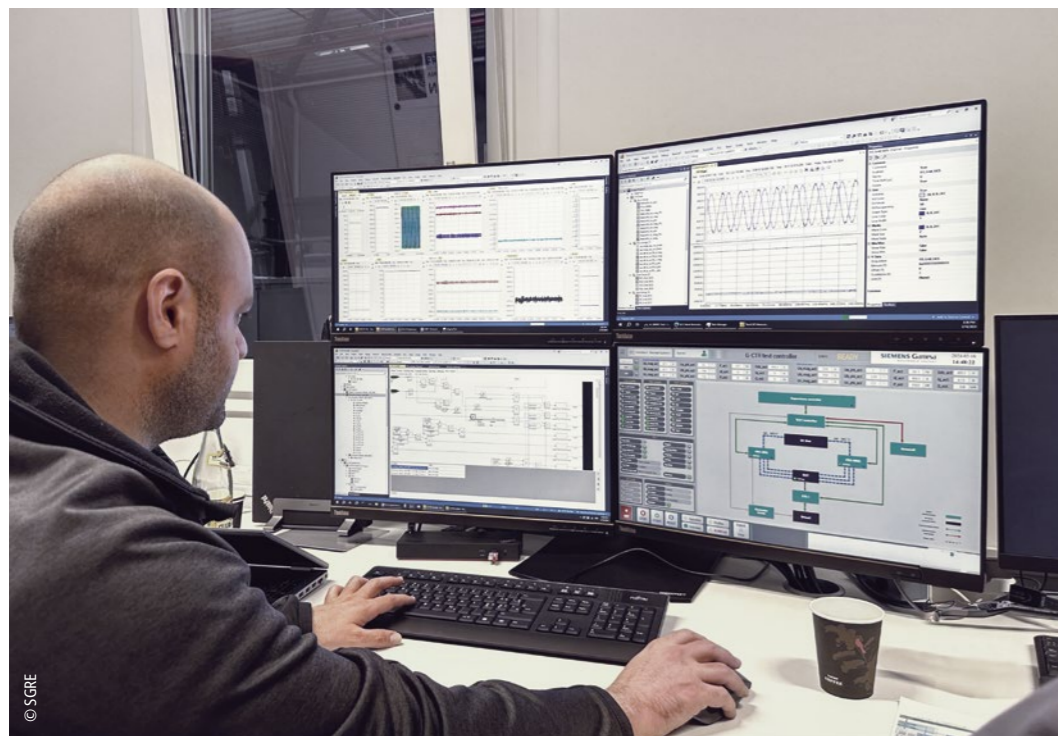

Beckhoff TwinCAT software plays an important role in the SGRE test rig, including TwinCAT 3 Scope View for data analysis (both top screens), TwinCAT 3 Target for Embedded Coder® (bottom left), and TwinCAT 3 HMI for convenient system operation (bottom right).

Exterior view of the G-CTR system from Siemens Gamesa

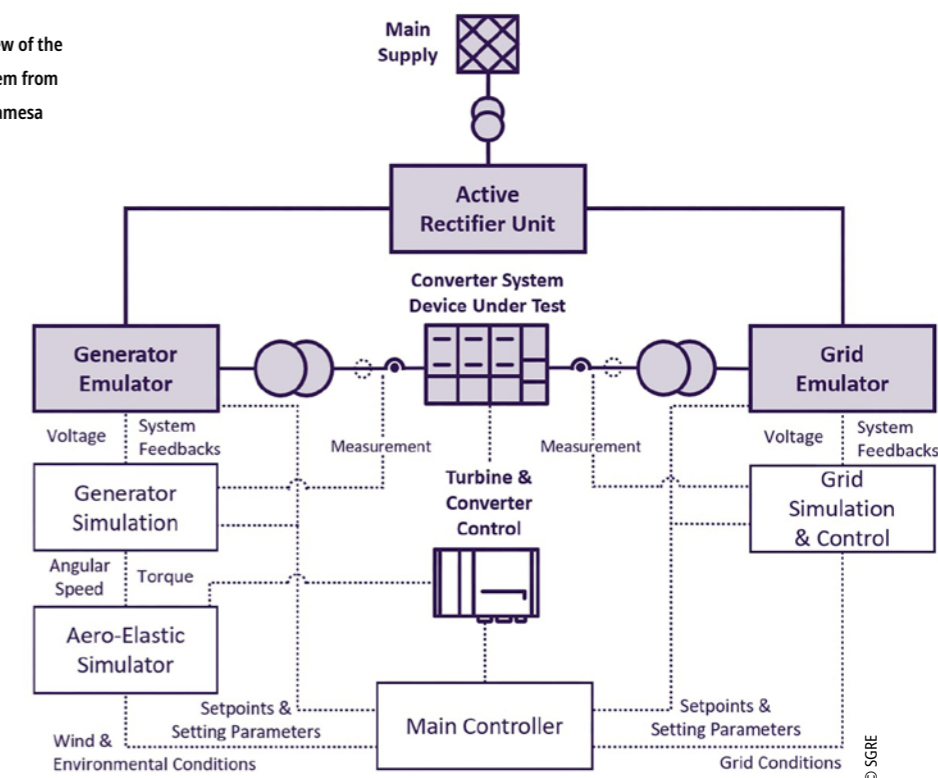

System structure of the Grid-Converter Test Rig

These PCs receive the specifications from the test scenarios from the test controller and execute modules developed in MATLAB® and Simulink® that were transferred to TwinCAT via TwinCAT 3 Target for Simulink® (TE1400). These simulation models simulate the raw values of the exact voltages and currents, including the phase positions and any other desired effects. The voltages and currents of the converter are measured via EtherCAT I/O modules and integrated into the simulation models for control and correction. The EL3783 grid monitoring terminal is used to measure 690 V directly on the grid side and the ELM3002-0205 high-voltage measurement terminal is used to measure up to 1,200 V on the generator side.

The entire wind turbine is mapped by Siemens Gamesa in real time using a simulation (BHawC) and communicates with the turbine controller, which in turn communicates with and controls the converter controller. The SGRE proprietary interface for controlling the systems was implemented via a TwinCAT C++ module and with TwinCAT 3 TCP/UDP Realtime (TF6311) and integrated in the test controller.

#### Automated test management, comprehensive visualization

The test controller enables fully automated execution of the large number of test scenarios by integrating test profiles. These profiles define the states that must be fulfilled as preconditions for the test, the states and signals to be passed through during the test as time sequences, and the states that are to be fulfilled again afterward (post-conditions). Hundreds of profiles are defined, selected in the visualization, and then automatically processed one after the other. All the operator has to do is observe the test sequences in the visualization and intervene if necessary in the event of an error. This not only simplifies the execution of the test scenarios, but also speeds them up and makes them reproducible. Reproducibility without manual intervention

is particularly relevant in order to be able to map scenarios from the field or submit them for certification.

The entire visualization was implemented with TwinCAT 3 HMI (TF2000). It enables the system to be started and stopped easily, test profiles to be managed and executed, and all states and signals from the various subsystems, emulators, and the converter to be diagnosed and visualized. In addition, TwinCAT 3 Scope View (TE1300) is used intensively to record and display individual signal curves from the high-resolution raw data in charts as required. For independent measurement via a redundant measurement system, this data is made available to external tools via TwinCAT 3 OPC UA (TF6100). This enables automatic triggering to start and stop recordings of the external measurement system as well as automatic execution and recording of the tests.

#### CPU optimizations and EtherCAT for fast sampling

The ACS6080 converter can be controlled, parameterized, and supplied with setpoints as magnitude and phase position via an EtherCAT interface. The power electronics can also be given the instantaneous values for the voltages with a sample time of up to 25  $\mu$ s via ABB's own communication interface. To utilize this interface, Siemens Gamesa became a member of the EtherCAT Technology Group (ETG) and has developed its own communication interface as an EtherCAT slave based on an FPGA and the EtherCAT IP core.

CPU optimizations are used to ensure that the instantaneous values for the voltages can be provided as quickly as possible by the simulation models. The CX2043 Embedded PC with AMD Ryzen™ processor is suitable for such highly deterministic applications – due to the powerful multi-core architecture and the use of specialized CPU instruction sets that enable precise and fast data processing. For this purpose, the processor provides instruction sets

such as AVX2 to speed up parallel calculations by means of vectorization. The Embedded Coder® from MathWorks® optimizes C/C++ code specifically for high-performance real-time systems by adapting it to the target hardware and using these special instruction sets. This results in higher efficiency and lower storage requirements. With TwinCAT 3 Target for the Embedded Coder® (TE1402), this optimized code can be transferred to TwinCAT modules and executed in real time.

#### Advantages of automation

From SGRE's point of view, the advantages of this automation solution are manifold: The use of EtherCAT and PC-based control technology from Beckhoff creates a high-performance and flexible test environment that can precisely map even highly complex and dynamic scenarios. The integration of MATLAB® and Simulink® models in TwinCAT enables seamless implementation of control and simulation requirements, while the comprehensive diagnostic and visualization options provided by TwinCAT 3 HMI and TwinCAT 3 Scope View ensure detailed monitoring and analysis of the test processes.

In summary, the innovative test environment from Siemens Gamesa – supported by automation technologies from Beckhoff – offers an efficient, reliable, and reproducible solution for testing and validating multi-megawatt converters for wind turbines. This not only helps to speed up the market launch of new products, but also ensures that they meet the stringent requirements of grid operators and regulatory authorities.



The ELM3002-0205 high-voltage measurement terminals (center) in use

More information:

[www.siemensgamesa.com](http://www.siemensgamesa.com)

[www.beckhoff.com/wind](http://www.beckhoff.com/wind)



The production site for the new production lines of ruhlamat Huarui Automation Technologies

PC-based control for producing flat wire motors for electric vehicles

## Producing large quantities flexibly and efficiently

In 2024, special machine manufacturer ruhlamat Huarui Automation Technologies unveiled the second generation of its mass production line for flexible stators with bar winding (pins). This enables extremely short production cycle and line changeover times, supported in many ways by the PC- and EtherCAT-based control technology from Beckhoff.

ruhlamat Huarui Automation Technologies (Changzhou) Co., Ltd. was founded in 2021. This Chinese-German joint venture offers intelligent manufacturing solutions and services for manufacturers of bar-wound stators. In line with the corporate strategy of "globalization, diversification, productization, digitization, platformization, and innovation capability", the aim is to drive industry development and transformation with innovative products and solutions.

Accordingly, the new generation of the stator production line is characterized by high flexibility and modular design. According to Qianfeng Yang, Director of electrical & software design department of ruhlamat Huarui

(Changzhou), 50% of the process stations allow for fast automatic changeover, resulting in a total line changeover time of less than 45 minutes. In addition, upgrades and further developments have been made to important process stations such as pin forming, insulation stripping, automatic lacing, and pin insertion as well as welding. This has significantly improved the overall effectiveness (OEE) and the degree of automation of the system. Overall, a production cycle time of 30 s can be achieved, which meets customer requirements for high efficiency and high quality. Furthermore, driven by the rapid growth of the electric vehicle industry, bar-wound stator technology continues to innovate, evolving from I-pin and hairpin to X-pin and S-winding.

### Automation technology as an enabler

Advanced, high-performance automation technology is of great importance for such highly flexible production lines. This is the only way to improve production efficiency, reduce resource consumption, and meet diversified product demands. For this purpose, ruhlamat Huarui used PC- and EtherCAT-based control technology from Beckhoff. This includes AX5000 servo drives, AM8000 servomotors, TwinCAT HMI with its numerous interfaces, C6030 ultra-compact Industrial PCs, multi-touch control panels, and various EtherCAT I/O components. The efficiency and flexibility of the EtherCAT communication system developed by Beckhoff have also been perfectly applied to the automated production line.

Qianfeng Yang, Director of electrical & software design department

“The comprehensive product portfolio has contributed to the successful implementation of the electric vehicle stator production line, adding significant value to the entire electric vehicle industry.”

According to Qianfeng Yang, Beckhoff's comprehensive product portfolio has contributed to the successful implementation of the electric vehicle stator production line, adding significant value to the entire electric vehicle industry. The C6030 ultra-compact Industrial PC offers high system stability and reliability for sophisticated control tasks, NC processes, and human-machine interactions in the production line. EtherCAT and the corresponding I/O components have enabled high-speed data transmission and high-performance real-time control, thus improving system responsiveness and simplifying wiring and installation processes.

According to the ruhlamat experts, the servomotors from the AM8000 series, with their high dynamic response and efficiency, perfectly complement the fast response times and advanced control algorithms of the AX5000 servo drives. This ensures stable operation of the entire system in sophisticated production environments. In addition, the TwinCAT software platform incorporates all necessary functions such as HMI, PLC, motion, and I/O into an integrated system, consolidates the development environment, simplifies development processes, and improves efficiency. Overall, this reduces compatibility problems, standardizes communication protocols, lowers maintenance costs, increases flexibility, and facilitates future machine upgrades and modifications.

More information:

[www.ruhlamat.com.cn](http://www.ruhlamat.com.cn)

[www.beckhoff.com/automotive](http://www.beckhoff.com/automotive)



Control cabinet with numerous Beckhoff AX5000 servo drives (below)

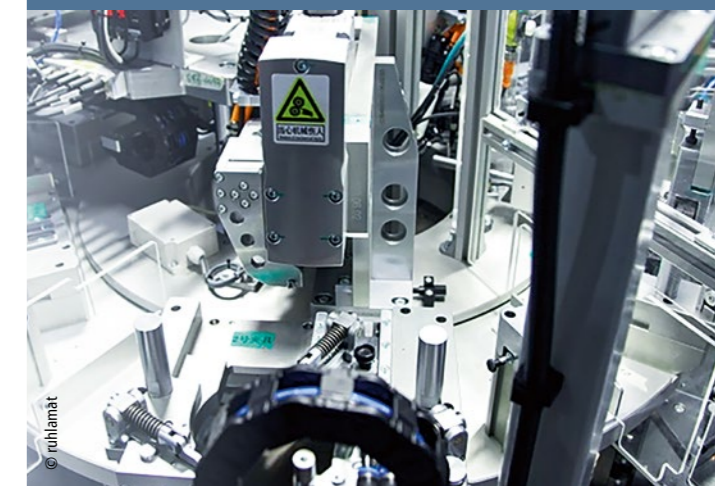

The mechanical machine layout



Nissei Plastic has converted all of its series injection molding machines to PC and EtherCAT-based control technology from Beckhoff.

PC-based control in the plastics industry

# PC-controlled injection molding: highly precise and flexibly adaptable to the latest IoT trends

Utilizing in-house developed control devices to balance advanced control technology with cost efficiency is an approach that has long prevailed among plastics machinery manufacturers. However, it hit its limits a while ago. Factors such as labor shortages, financial challenges, and the need to adapt to the latest technologies have resulted in a trend for open automation systems from experienced specialists. Nissei Plastic Industrial Co., Ltd. (Nissei Plastic), an injection molding machine manufacturer based in Nagano Prefecture, Japan, is implementing this shift using PC and EtherCAT-based control technology from Beckhoff.

The German Industrie 4.0 initiative, which highlights the importance of standardization and interconnectivity in manufacturing, underpins the success of control platforms with open architecture. Across various industries, including the field of injection molding machines, concrete implementation is gaining momentum. Notably, OPC Unified Architecture (OPC UA) has become the primary communication framework for Industrie 4.0 standardization. In this context, Nissei Plastic has taken what it describes as a pioneering step: developing an advanced control system based on Beckhoff Industrial PCs with TwinCAT software and EtherCAT open communication technology. Moreover, Nissei Plastic became one of the first manufacturers worldwide to meet the requirements of the OPC UA standard.

## Why opt for an open architecture?

Plastics are an essential material used in products such as smartphones, televisions, PCs, and automotive components. Depending on the size and type of final product, the injection molding machines required for production range from compact to massive systems with clamping forces exceeding 7,000 tons. Nissei Plastic is one of the world's leading manufacturers of such injection molding machines and regards the transition of its control platform to an open architecture as a pivotal decision.



The CX5140 Embedded PC forms the powerful control core of the injection molding machines.

Like many other manufacturers, Nissei Plastic originally developed in-house microcontroller boards for their customized control systems. However, this approach required the company to manage all hardware components internally, presenting a considerable challenge. They had to address issues such as component discontinuation, revision changes, and technical problems unrelated to their primary expertise in injection molding technology. Moreover, keeping up with the latest CPU technology updates added to their concerns, necessitating constant hardware development. Nissei Plastic therefore decided to focus its resources on software development and use scalable standard control hardware.

#### Selecting PC and EtherCAT-based control as the solution

After comprehensive benchmarking, Nissei Plastic found that Beckhoff's PC-based control in combination with the open and fast EtherCAT communication system was best suited to meet its current and future demands. The main reasons for this decision included:

- High performance: The production of injection molded parts with maximum repeatability and high quality requires a highly deterministic control system with cycle times of 125 µs or lower. According to the experts at Nissei Plastic, PC-based control from Beckhoff offers the required performance, not least due to its in-depth development and production expertise. This is because Beckhoff develops and manufactures the IPC motherboards in-house, creates the TwinCAT automation software for real-time control, and utilizes its unparalleled expertise in fieldbus communication as the inventor of EtherCAT. This extensive and long-standing experience is crucial.

Hozumi Yoda (l.), President of Nissei Plastic, presents the customer-specific signal distribution board with the EJ series EtherCAT plug-in modules.  
Hans Beckhoff (r.), Managing Director of Beckhoff Automation, presents the CX5140 Embedded PC used as the control core.



- EtherCAT: Specifically in Japan, EtherCAT has been a de facto standard for many years. This offers Nissei Plastic significant flexibility in selecting the most suitable suppliers and components for its injection molding machines. Collaborating with Beckhoff ensures Nissei receives top-notch support for any EtherCAT-related queries and early access to future cost-saving EtherCAT technologies, such as EtherCAT P. EtherCAT emerged as the only technology capable of delivering the required speed and accuracy while maintaining high flexibility and broad fieldbus coverage. Moreover, the scalability of EtherCAT facilitates future system expansions and upgrades, increasing the company's investment security.

According to Nissei Plastic, in order to remain competitive in the plastics industry, it is crucial to develop cost-efficient machines in terms of engineering, production, and maintenance. In addition to leveraging economies of scale when relying on standard automation hardware, PC-based control from Beckhoff offers various options for minimizing overall costs:

- Centralized and scalable control hardware: The Beckhoff control system is based on a centralized and finely scalable computer platform. As a result, it is possible to choose from a broad CPU portfolio to match the application-specific requirements. If new functions such as machine learning are added, these additional functions can be programmed in TwinCAT in various programming languages including IEC 61131-3, C++ or MATLAB® and Simulink® and then executed as software modules in real time. If higher computing power is required, this can be easily accomplished by migrating to a new IPC or CPU version without changing the existing TwinCAT project or the intended automation architecture.

- EtherCAT plug-in modules: Nissei Plastic sees great advantages in the EtherCAT plug-in modules of the EJ series, which integrate several I/O functions into a single compact board – the signal distribution board. This shortens the development and time-to-market times, as the standardized signal distribution board can be used to implement different machine types with expansion variants on a single basis. Furthermore, this approach eliminates wiring costs and errors and provides a simple means of customization by plugging in new modules without having to completely redevelop the board – offering significant benefits for the company.

#### Converting standard machines to PC-based control

The development of EtherCAT-compatible injection molding machines equipped with Beckhoff technology began back in 2016. The following year – and then globally in 2018 while announcing its partnership with Beckhoff – Nissei Plastic unveiled the new machine model FNX-IV (hydraulic version) in Japan. This marked the first milestone of integrating Beckhoff technology into its machines. Subsequently, the electric NEX-V series was introduced, meaning that all series-produced machines from Nissei Plastic now feature Beckhoff technology.

The FNX-IV and NEX-V models use the cost-efficient CX5140 Embedded PC with a quad-core Intel Atom® processor as the control core. This PC serves as the EtherCAT master, enabling extremely fast control cycles. Previously, analog communication limited the speed and precision of control. According to Nissei Plastic, however, switching to EtherCAT allowed all applications, including peripheral devices, to be fully integrated into a high-speed network, significantly improving precision, noise resistance, and molding quality.

Additionally, TwinCAT allowed various functions to be integrated into PC-based control modules, ensuring future scalability without hardware modifications. Nissei Plastic also values the open nature of TwinCAT as an engineering environment, e.g., with a wide range of options for integrating existing source code. TwinCAT 3 C++ converts many of the software assets previously used on the self-developed microcontroller board directly into new control modules. These modules are combined with TwinCAT 3 PLC to create a new control system with minimal effort. As a result, Nissei Plastic has succeeded in developing a highly flexible system in a short space of time.

#### Nissei Plastic's IoT strategy

Inspired by the German Industry 4.0 initiative, industries worldwide are working towards standardized data interoperability across manufacturers. The central framework for this movement is OPC UA, but it does not fully address the needs of all production plants. To close this gap, industry-specific companion specifications have been developed in different sectors:

- plastics machinery: EUROMAP
- machine tools: umati
- industrial robots: OPC UA for Robotics
- packaging machines: PackML

Recognizing the urgency of OPC UA adoption, Nissei Plastic led the way, presenting an OPC UA-based EUROMAP solution together with Beckhoff back in 2018. In 2019, the machine builder launched its new TACT5 controller

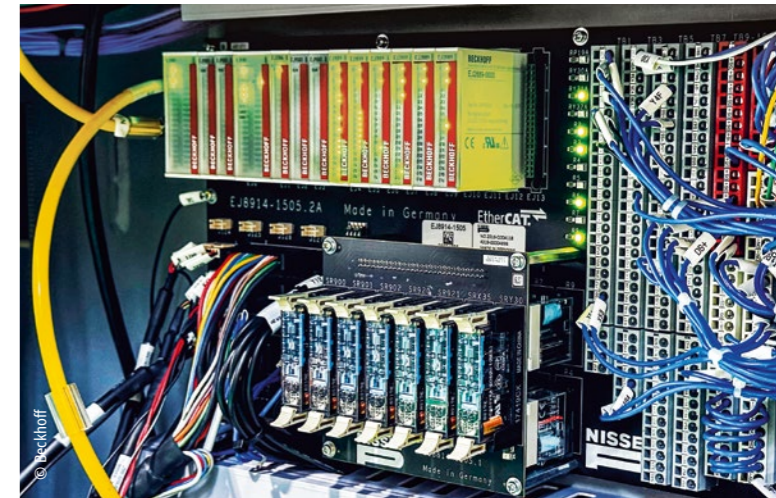

The EtherCAT plug-in modules of the EJ series (above) – mounted on the customer-specific signal distribution board – result in a highly compact, standardized, and yet flexible I/O level.

with OPC UA as a standard feature. According to Nissei Plastic, this open technology approach not only offers greater benefits for the user, but also fosters collaboration across Japan's plastics industry and ensures long-term competitiveness.

#### Partnership with Beckhoff

Nissei Plastic has high expectations for its partnership with Beckhoff. Moving forward, the company seeks deeper collaboration with Beckhoff, including beta testing new products to optimize cost and performance. Nissei Plastic attaches great importance to a long-term, trusting, and cooperative business relationship. In addition to sales and technical support from local Beckhoff experts in all relevant production countries, this also includes close contact with various Beckhoff specialist departments.

More information:

[www.nisseiplastic.com/en](http://www.nisseiplastic.com/en)

[www.beckhoff.com/plastics](http://www.beckhoff.com/plastics)

PC-Based control optimizes parts handling on plastics machinery

## Control cartesian robots dynamically and precisely

NEO is a cartesian robot developed entirely by INAUTOM Robótica in Portugal for parts removal on plastics machinery. Its aim is to increase system productivity. The company relied on AM8000 synchronous servomotors, the AX8000 multi-axis servo system, TwinCAT software, and the expertise of the long-standing Beckhoff distributor Bresimar Automação to create this robot.

The NEO 10 cartesian robot increases the dynamics and precision of pick-and-place applications with AM8000 synchronous servomotors, the AX8000 multi-axis servo system, and TwinCAT 3.



NEO 10

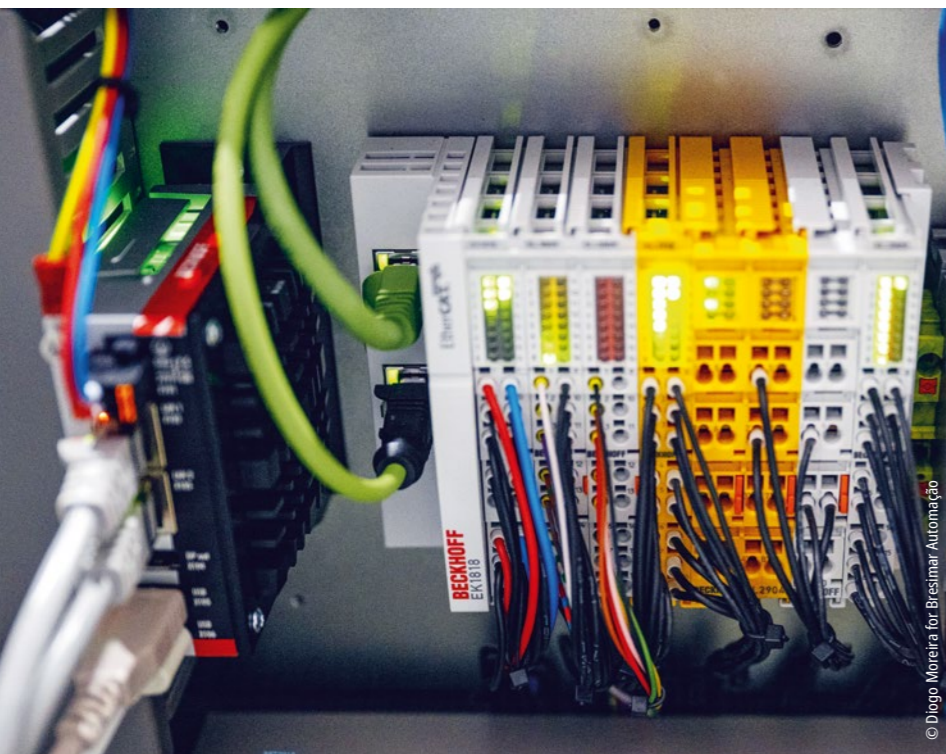

© Diogo Moreira for Bresimar Automação

Thanks to the compact dimensions of the C6015 ultra-compact Industrial PC (left) and the EtherCAT Terminals (right), no separate control cabinet is required.

The plastics industry is faced with the challenge of constantly increasing the efficiency and flexibility of its machines and processes. "This makes automation an essential factor in keeping machine suppliers and producers competitive," says Fábio Roleiro, Development Engineer at INAUTOM Robótica, emphasizing the importance of the project. With this in mind, INAUTOM Robótica – which is the only Portuguese company specialized in the production and integration of cartesian robots and other types of robotic solutions into plastic injection molding machines – has entered into a strategic partnership with Bresimar Automação, a company that has represented Beckhoff Automation in Portugal for more than 20 years. The aim of the collaboration was to increase the working speed of the cartesian robots using advanced control and motion solutions from Beckhoff. "As a result, we've created a comprehensive, future-proof automation solution for our entire family of cartesian robots," says Fábio Roleiro.

#### Flexibility thanks to an open automation system

The cartesian robots in the NEO series are optimized for the fast and precise removal of injection molded parts, thus increasing machine productivity. Key performance indicators such as high removal and placement accuracy and speed are crucial elements in reducing cycle time. All the components of the cartesian robots have been designed to ensure the system is mechanically robust enough for integration into plastics machines.

The components that the company relies on include a C6015 ultra-compact Industrial PC as the controller, AM8000 synchronous servomotors in combination with the AX8000 multi-axis servo system, and various EtherCAT Terminals from the EL series and EtherCAT Box modules from the EP series. "Working



© Diogo Moreira for Bresimar Automação

With the current controllers implemented in the hardware and 16 kHz clock frequency of the position controller, the AX8000 multi-axis servo system can position the axes of the cartesian robot with high precision and dynamics.

with these plus TwinCAT 3 as the automation platform, the engineers at INAUTOM Robótica were able to deal with all the technical challenges they were faced with," says Gervásio Monteiro, Beckhoff Brand Manager at Bresimar Automação.

An important aspect in the development of the NEO series was to achieve the greatest possible flexibility so that handling solutions could be adapted to customer layouts and processes. "With payloads of up to 70 kg, the cartesian robots are also a great option for applications outside the plastics industry," says Fábio Roleiro, highlighting the wide range of applications for the series. The finely graduated portfolio of motors and drives enables adaptation to different payloads. In terms of the software, standardization across all sizes was achieved thanks to TwinCAT. To achieve precise movements that also meet the high requirements placed on speed and acceleration, the gantry axes (X, Y, and Z) are equipped with AM8000 synchronous servomotors. With their dynamics and high holding torques, the servomotors are ideal for applications that require precision and efficiency. Encoders integrated into the servomotors as a feedback system provide precise position values, which are transmitted to the AX8000 multi-axis servo system in real time (communication cycle of 62.5 µs) via EtherCAT and the space-saving, weight-reducing One Cable Technology (OCT) connection technology.

#### Adaptable hardware and software

With dimensions of just 82 x 82 x 40 mm, the C6015 ultra-compact Industrial PC is the most compact model in this series from Beckhoff. It also provides versatile installation options. "INAUTOM Robótica exploits limited installation space with the industrial PC," says Gervásio Monteiro. Despite the small form



© Diogo Moreira for Bresimar Automação

For wireless communication with the robots, INAUTOM Robótica uses the Beckhoff CU8210-M001 cabinet dome for industrial WLAN and mobile radio components.

factor, Intel Atom® quad-core processors provide sufficient computing power to calculate the axis movements of the cartesian robot dynamically and synchronously with TwinCAT. "With Windows 10 IoT and TwinCAT/BSD operating systems available, as well as Linux® in the future, we can also adapt to the software requirements and operating environments of our customers," says Fábio Roleiro, emphasizing the flexibility of the NEO series.

INAUTOM Robótica automates the robots with a TwinCAT 3 PLC/NC PTP 10 (TC1250) and the TwinCAT 3 HMI server (TF2000) for visualization. The user interface developed in HTML5 provides a complete solution for managing and operating the robot systems. HTML5 enables both combination with mobile operating devices and integration into an existing browser-based HMI for plastics machinery. This saves on the cost of an additional device for commissioning the robot. "In addition, the HTML5-based visualization simplifies user interaction with the system. The intuitive operation reduces the learning curve for operating personnel, which means that it also helps increase efficiency overall," says Gervásio Monteiro. Additionally, PC-based control as an open control platform gives INAUTOM Robótica the assurance that it will be able to accommodate future customer requirements as well.

#### Safety in accordance with IEC 61508 and Euromap 67

INAUTOM Robótica relies on TwinSAFE as its safety technology for implementing safety requirements in accordance with IEC 61508 (SIL3). It uses EL1918 TwinSAFE Terminals (4-channel digital input) and an EL2904 (4-channel digital output). This means that the robots can be integrated into the plastics machines in accordance with the Euromap 67 standard (Electrical Interface between Injection Moulding Machine and Handling Device/Robot). "This stan-



© Diogo Moreira for Bresimar Automação

The One Cable Technology (OCT) connection for the AM8000 synchronous servomotors saves valuable installation space.

dard is essential for the safe electrification and coding of robot operations," states Fábio Roleiro.

"The solution based on drive and control technology from Beckhoff exceeds our performance requirements and meets the high safety standards set out by IEC 61508 (SIL3) and Euromap 67," says Fábio Roleiro in summary. Integrating Beckhoff's control and drive technology into INAUTOM Robótica's cartesian robots enables pick-and-place operations to achieve higher levels of speed and accuracy. INAUTOM Robótica's customers benefit from reduced cycle times, resulting in a significant improvement in the productivity of plastic injection molding machines. This is because the modular design of the NEO robots allows them to be customized to specific customer layouts and processes in terms of payloads and dimensions. "Our project shows how important exceptional technologies are for meeting specific market requirements," explains Fábio Roleiro, "and that strategic partnerships and innovation play a crucial role in the continuous development of industrial automation."

More information:

[www.robotica.inautom.pt/en/robots](http://www.robotica.inautom.pt/en/robots)

[www.beckhoff.com/plastics](http://www.beckhoff.com/plastics)

EtherCAT and PC-based control on concert tours with the Fire Snake

## Advanced automation technology ensures safe pyrotechnic effects in sync with live music

The linear burn system Fire Snake is capable of creating a 3.35 m wall of fire with individual control of flame shape and height, while a truss structure with winches allows the units to be adjusted at different angles to create dynamic stage designs.

Image Engineering, based in Curtis Bay, Maryland, designs spectacular pyrotechnic effects for top bands. Music, lighting, lasers, and fire combine to fully immerse the audience in the concert experience. To be able to synchronize the special effects in real time and to stop them at the touch of a button any time, the company relies on the integrated control and safety technology from Beckhoff.

Image Engineering plays a starring role behind the scenes of some of the most outrageous concert productions of the past few years. The most notable of which were Disturbed's "Take Back Your Life" rock concert tour of 2023 and Trans-Siberian Orchestra's 2024 winter tour, "The Lost Christmas Eve." The Image Engineering team say they push the boundaries of special effects technology by integrating advanced automation and controls into their projects. The company's growth has been driven by an engineering-centric approach. "The company's owners are all engineers, and since the begin-

ning, engineering has been central to who we are," says Ian Bottiglieri, Vice President of Operations, Image Engineering. "That sets us apart from our competitors in the live event space."

The Fire Snake concept developed from the need for never-before-seen, jaw-dropping pyrotechnic effects by top-billed band Disturbed. Other than the typical lighting, the fire effects were going to be the only stage equipment to provide key visual effects. "I remember sitting in our conference

room having conversations with the band and asking, 'All right, where is the video screen going to be?' " recounted Nick Hock, Director of R&D and Installation/Integrations, Image Engineering. "And their answer was, 'There is no video screen. The fire will be the only visuals for the show.'"

While it was up to Image Engineering to work with the Disturbed production team to provide the visual experience for the Disturbed tour, they also had to ensure that the Fire Snake operated safely and reliably in numerous



Within four months, Image Engineering had to ensure that the Fire Snake would operate safely and reliably in many different environments at different temperatures and orientations.

environments, temperatures, and orientations – and the timeline for project realization was less than four months.

#### A trial by fire for engineers

Image Engineering poured a tremendous amount of R&D into every aspect of the Fire Snake. This included exactly how to safely feed the appropriate amount of propane at a pressure of up to 22 psi and maintain a steady pilot light no matter what orientation the Fire Snake is in. The Fire Snake design required replacing traditional burn bars with advanced, responsive burners that could provide more dynamic fire effects. The resulting linear burn system is capable of creating a 3.35 m (11-foot) wall of fire with proportional control for variable height and shape up to 1.20 to 1.80 m (4' to 6'). In addition, two large burst valves can produce rolling fireballs.

The Fire Snake had to be compact and modular to make it easy to transport, assemble, and integrate with existing stage structures from show to show. It was crucial for the automation and safety systems to manage complex fire effects, and provide safety assurances to local officials. After various meetings with the Beckhoff entertainment industry team, Image Engineering decided to work with the automation experts to bring the Fire Snake to life. They would leverage advanced PC-based control technology with the integrated safety technology TwinSAFE backed by the EtherCAT industrial Ethernet system, because of its superior flexibility in comparison with conventional control technology.

#### The Fire Snake comes to life

On the Disturbed tour, the Fire Snake had to actively move and change shape according to routines that synced up with the flow of the setlist. When the band first started playing, the Fire Snake rig would slowly come to life and build into more dynamic movement. For that purpose, five segmented Fire Snake units are bolted to a custom truss structure with five winches to change the degree of angle for each unit. A little bit more than a centimeter (half an inch) of clearance between each unit allows free movement yet maintains a continuous, unbroken look to the linear fire effects.

Image Engineering's Touring Accumulator System (TAS) manages the propane from liquid to vapor and feeds it to the effect heads. When adjusting



The propane-powered burners generate continuous flames with an adjustable height of up to 1.80 m, as well as rolling fireballs using bursting valves.

Fire Snake units by 45 or 50 degrees, fuel and fire behave differently and the control system has to maintain the effects and safety. "The Beckhoff system provides the flexibility to not only meet the baseline standards for flame effect systems such as those outlined in the NFPA 160 standard for fire effects but exceed them in many local jurisdictions across the U.S.," says Nick Hock.

The Fire Snake features numerous safety measures to ensure trouble-free performances, which are integrated into the control platform via TwinSAFE I/O terminals. One e-stop can halt the entire rig, and the operator can see all safety-relevant status information with a glance at the control console. "It was extremely reassuring to local fire marshals to see a safety system demo and witness the entire Fire Snake shut down to a controlled stop at the push of a button," Hock says.

Installed in the Fire Snake's shippable case control boxes are CX5140 and CX8190 Embedded PCs with directly attached EtherCAT I/O as primary and backup controllers respectively. EtherCAT and Safety over EtherCAT (FSoE) establish real-time communication and synchronization throughout the entire system including safety devices, and equipment used for lighting and other stage effects. "Real time performance is critical for us, because we have to keep perfect time with the band's music and lighting," Nick Hock says. "If we were out of sync even a couple milliseconds, audiences would notice. A proven technology like EtherCAT ensures that the Fire Snake keeps perfect time with the music."

Therefore, the Fire Snake utilizes various EtherCAT I/O modules – supported by TwinCAT software – to connect flexibly with devices from other networks such as DMX and OSC. For example, Image Engineering uses the EL6851 single channel DMX interface to trigger the Fire Snake's flame effects.

#### The show must go on

Since its completion, the Fire Snake met the requirements for rapid setup and dismantle during multiple tours for Disturbed and Trans-Siberian Orchestra. For example, Image Engineering was responsible for bringing multiple Fire Snakes on the road to 56 Trans-Siberian Orchestra concerts in just 40 days on both the East and West Coasts of the U.S. – at the same time.

The Beckhoff system's ability to operate reliably in extremely high ambient temperatures became another critical benefit on the road, especially for concerts in the summertime. "The heat resiliency of the embedded PC hardware is impressive," Claire Bowman, Associate Director of Engineering, Image Engineering, says. "We've used other embedded systems before that had performance issues on rooftops in Las Vegas when the temperatures reach as high as 49° C (120°F). However, the Beckhoff system always performs without fail."

In addition to extreme climates, unreliable power in different cities was also a major concern for Image Engineering. "We experienced serious power quality issues on our rig at different stops on the tours," Bowman says. "This was causing major performance issues at the worst possible time. But with troubleshooting help from the Beckhoff team and the PS2001 power supply with built-in EtherCAT interface, we were able to solve it and establish reliable power supply no matter the quality of the incoming feed. We also installed a large CU8110 capacitive uninterruptable power supply (UPS) to make sure that our power distribution was good."

"We now have outstanding troubleshooting capabilities with EtherCAT," Nick Hock says. "We can simply look at the Fire Snake's HMI and see which nodes are properly connected and those that require troubleshooting. EtherCAT precisely localizes the exact source of any issue in the system. Previously, problem resolution often took hours, it now takes just minutes with EtherCAT and TwinCAT."

With a user-friendly programming environment integrated with Microsoft Visual Studio®, TwinCAT 3 significantly reduced Image Engineering's software development time. "We can create robust systems that are also relatively easy to program – especially because we don't have to create our own building blocks to do basic functions," Claire Bowman says. "These building blocks are already there for you in TwinCAT's software libraries."

Compared to when the company relied heavily on their own embedded board development, the standard PC-based control hardware has dramatically cut their hardware development time. "We were able to have 90 percent of the products working immediately with very little rework that we needed," Ian Bottiglieri says. "In addition, the ease of programming and setup reduced development and commissioning time by nearly 50%."

#### Encore for the Fire Snake

The Fire Snake received universal acclaim from audiences, performers, and industry experts. "The band members of Disturbed loved it and the audiences reacted very positively to it as well," Nick Hock says. "Everyone just fell in love with it." In 2024, the recognition culminated in the honor of a Parnelli Award for Pyrotechnics Special Effects Company of the Year for Image Engineering's sister company, Image SFX. The Parnelli is the most significant honor live event companies can win in their industry.

The collaboration with Beckhoff enabled Image Engineering to push the boundaries of what was possible in pyrotechnics. The Fire Snake can now be deployed as a standard solution or highly customized to suit individual productions. It can also easily integrate with other stage control systems used throughout the entertainment industry.

Beckhoff and Image Engineering teams (from left to right): Jay McNeil, Regional Sales Engineer, (Beckhoff USA); Ian Bottiglieri, Vice President of Operations; Claire Bowman, Associate Director of Engineering; Nick Hock, Director of R&D and Installation/Integrations (all Image Engineering); Arthur Peterson, Application Engineer, and Jason Toon, Entertainment Industry Specialist (both Beckhoff USA)



Installed in the Fire Snake's shippable control boxes are space-saving CX5140 and CX8190 Embedded PCs with directly attached EtherCAT I/O (CX5140 shown).

More information:

[www.imageengineering.com](http://www.imageengineering.com)

[www.beckhoff.com/entertainment-industry](http://www.beckhoff.com/entertainment-industry)

PC-based control and EtherCAT accelerate OLED material development

## Triple the throughput with nanometer-precise deposition rates



After development using virtual methods, OLED materials are vigorously tested in display sample production to meet the exact customer specifications.

In the race to develop next-generation display technologies, one of the biggest challenges is creating and validating new materials. OTI Lumionics from Canada is accelerating this time-consuming process with automation technology from Beckhoff. Through increased efficiency in test production, the company is now able to complete the validation process for its high-end OLED materials more quickly.

“We’re developing breakthrough materials by design, using quantum simulations, machine learning, and real-world testing in pilot production,” says Michael Helander, CEO and President of OTI Lumionics, located in Mississauga, Ontario. These materials will enable breakthrough features in a range of electronics – from smartphones with under-display cameras to state-of-the-art automotive displays. “Working closely with partners like Apple, Samsung, and LG, we’re creating the key enabling materials for next-generation OLED displays in consumer electronics and automotive applications,” Helander adds.

### Test process under scrutiny

To enable this kind of success, OTI created EPOC-auto, their innovative material testing platform for pilot production. “Before developing EPOC-auto, we were struggling with different results from different operators,” said Terry Xu, VP Engineering at OTI Lumionics. “It was difficult to repeat the same OLED structure and thus to fine-tune some critical parameters. The systems were mostly idle because the device structure must be completed in one run during the day. As a result, the operating cost of these tools was very high, while the yield of working OLED samples was low.”

Automating the process required overcoming a complex set of challenges. The system needed to handle 20 substrates with completely different layer structures automatically while maintaining movement accuracy of 0.1 mm for substrate and mask alignment – a level of material deposition control that would be difficult even in a single operation, let alone sustained across continuous testing cycles. In addition, the system needed to control multiple material sources simultaneously, each requiring its own precision controller for managing deposition rates at nanometer scale. To get consistent results, hundreds of sensors and moving elements had to work in perfect coordination.

Adding to the complexity, the system also needed to adapt to changing experimental requirements. “Because of the experimental nature of our business, our objectives can vary daily,” explained Terry Yang, Senior Mechatronics Engineer. “And this means we needed a system that could be adjusted and upgraded at a rapid pace.”

### Industrial automation in a scientific environment

To address these challenges, OTI made the decision to standardize on the universal PC-based control platform from Beckhoff. At the heart of the solution

is the CX2033 Embedded PC, which manages the entire automated testing process while providing the precise, deterministic control needed for nanometer-scale material deposition. This is complemented by the real-time EtherCAT industrial Ethernet system for seamless integration of sensors, actuators, and scientific instruments.

The broad spectrum of EtherCAT Terminals enables communication with third-party devices and helps to bridge the gap between scientific instruments and automation. The flexibility these interfaces provided for integration, was crucial given the unique requirements of semiconductor research and development.

**EtherCAT integrates scientific instruments**

OTI leveraged EL6021 serial interface terminals, which provide RS422/RS485 communication at up to 115.2 kbaud, to enable high-speed data exchange with specialized equipment like quartz crystal microbalances and vacuum controllers. EL3024 4-channel analog input terminals, meanwhile, deliver 12-bit resolution with electrical isolation, providing accurate monitoring of multiple deposition parameters simultaneously while protecting sensitive measurement equipment. The EL3318 8-channel thermocouple input terminals enable precise temperature monitoring across multiple thermal zones with built-in linearization and cold junction compensation.

The OTI Lumionics team and Beckhoff at the facility in Mississauga, Ontario: (from left) Rui Zhang (Beckhoff) Terry Xu, Michael Helander, Terry Yang (all OTI) and Gleeson Kathir (Beckhoff).

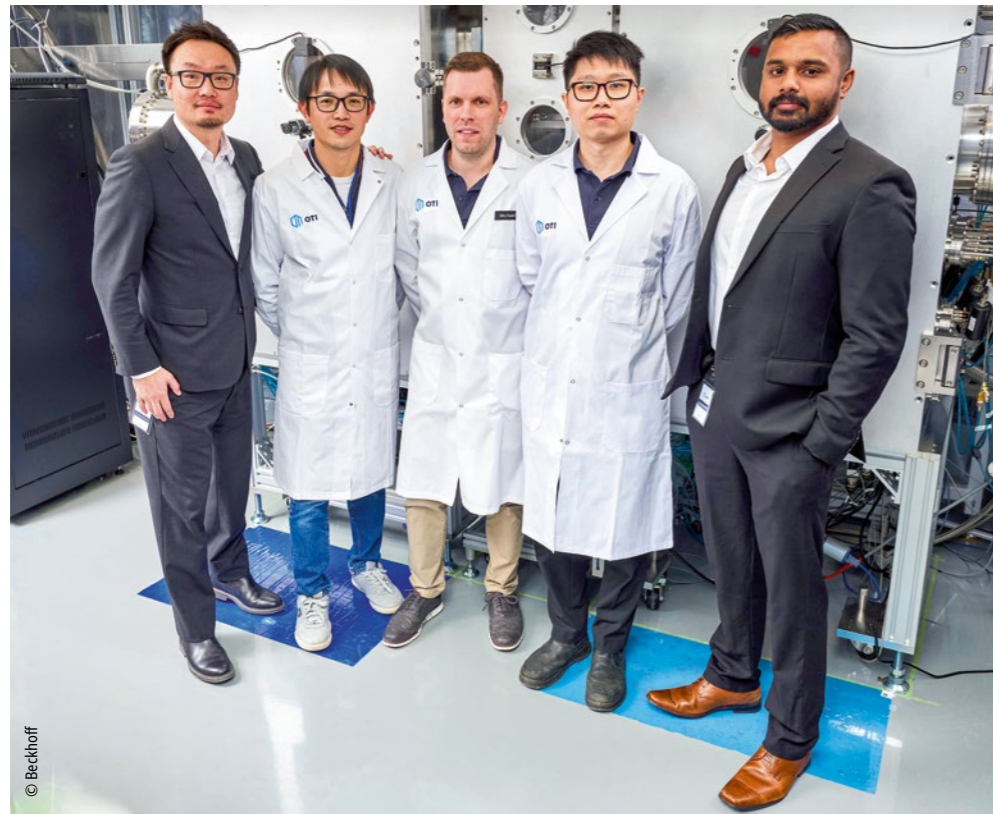

To ensure top-tier material quality, many OLED display samples are manufactured and evaluated.

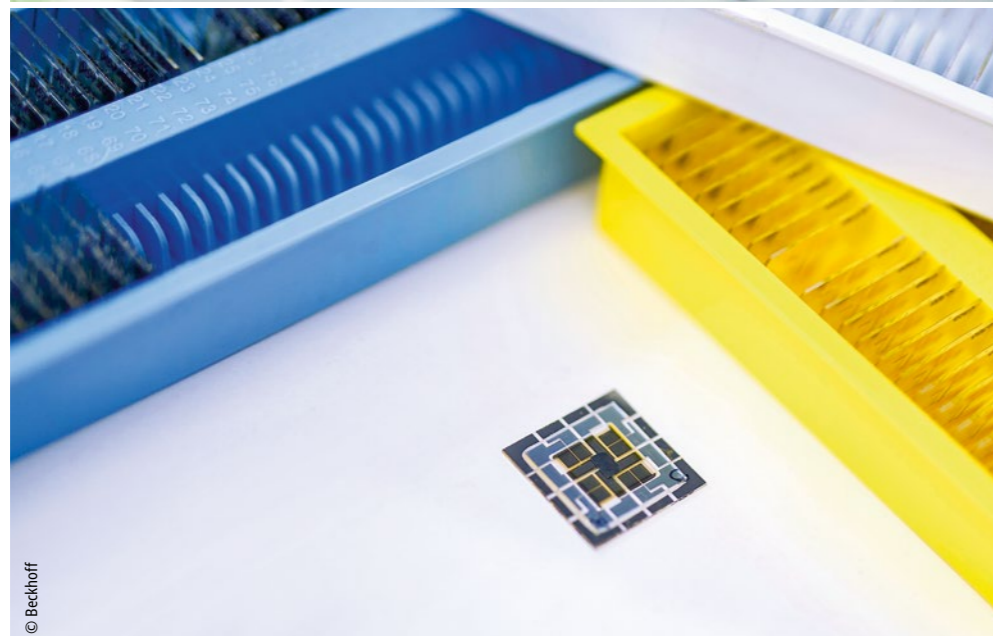

This combination creates a robust measurement and control infrastructure that maintains accuracy down to the nanometer scale required for OLED material development. The terminals' compact design and direct EtherCAT implementation throughout the system also simplify cabinet design while providing the flexibility to add interfaces for new measurement points as testing requirements evolved.

Building on this streamlined architecture, the motion control system integrates Terminals for precise positioning control with AM8122 servomotors. "The One Cable Technology for the compact servomotors makes wiring clean, while the serial communication libraries allow easy integration of third-party components," Terry Yang explains.

During the implementation, OTI worked closely with Rui Zhang, P.Eng., Application Engineer & Drive Technology Products Specialist at Beckhoff Canada, who assisted with integrating the AM8122 servomotors and software configuration in particular. The motion control system also incorporates five AX5201 servo drives that, together with the motors, form the critical interface between the mechanical system and the control system. With current control cycles as fast as 62.5 µs, they deliver the required performance for highly dynamic positioning tasks.

OTI benefits from the flexible feedback interface of the AX5000 series, which supports connections with various feedback systems, including resolvers and high-resolution encoders. This flexibility, combined with the drives' variable parameterization capabilities for current and speed filters allowed the engineering team to fine-tune the motion control for the nanometer-precision requirements.

"OTI's strong technical foundation and experience with object-oriented programming principles made the integration process exceptionally smooth," Rui Zhang says. The system leverages TwinCAT automation software, which integrates real-time control with PLC, NC, and CNC functionality on a single platform. The software's engineering environment enables configuration, programming, debugging, and diagnostics of all connected automation devices. "We exclusively use Structured Text because of its close resemblance to object-oriented programming," notes Terry Yang. "This makes our software easy to read and debug because of the concise programming style."

**From complexity to clarity**

"EPOC-auto can run 24/7 with minimal operator intervention," Terry Xu says, explaining that it has more than three times the throughput of a semi-automation or manual system. "So far, it has run in continuous operation without an error. Moreover, the testing repeatability is twice as good as our previous systems." Enhanced data collection and analysis capabilities have proven particularly valuable for evolving the test process.

"This automated testing platform has fundamentally changed how we innovate," says Xu. "When you can triple your testing output while improving precision, you're not just solving today's challenges – you're accelerating the future of display technology."

Besides AM8x22 servomotors with OCT, the motion control platform in test production also includes the AMI8122 integrated servo drive with servomotor, output stage, and fieldbus connection in a compact design.



Beckhoff AX5201 servo drives support fast and highly dynamic positioning tasks required for material testing.

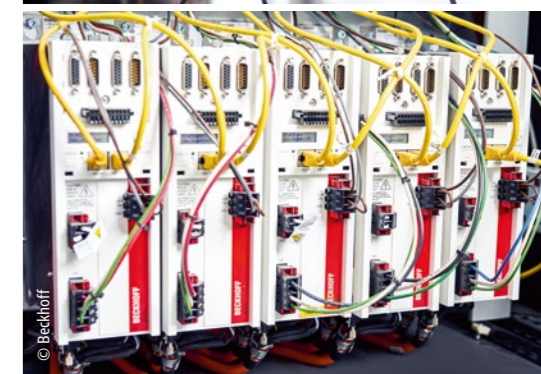

For high-speed data exchange with specialized scientific equipment, OTI Lumionics uses a wide variety of EtherCAT Terminals on the material testing platform.

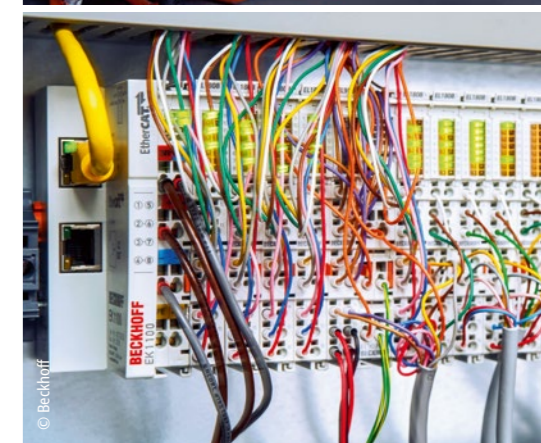

More information:  
[www.otilumionics.com](http://www.otilumionics.com)  
[www.beckhoff.com/ethercat](http://www.beckhoff.com/ethercat)



Jan-Willem van den Broek (sales at Beckhoff Netherlands), Stefan van Amerongen (Product Lifecycle Architect at Additive Industries), and Stijn de Bruin (Sales Engineer at Beckhoff Netherlands) in front of the MetalFAB 3D printer (from left to right)

PC-based control technology in additive manufacturing

## Open control solution combines precision with graphical programming

As an open control platform, PC-based control supports different engineering approaches, including low-code programming with frameworks such as Cordis SUITE. The machine builder Additive Industries uses this to create the code for the TwinCAT runtime of its MetalFAB 3D printers. When it comes to automation technology, the company relies entirely on Beckhoff controls, I/Os, and drive technology.



Additive Industries and Cordis rely on a CX5230 Embedded PC with TwinCAT for the control technology.

Low-code programming, which refers to software development based on models in a graphical environment, is a long-established approach in IT. Cordis applies this approach in its Cordis SUITE platform for OT systems, where the code for the TwinCAT runtime is automatically generated from state-machines and activity diagrams.

#### PC-based control – open, right from the start

“Low-code programming started much later in OT than it did in IT because traditional manufacturers shielded their hardware for a long time,” explains Jan Peter Meeuwse, Chief Operating Officer of Cordis. PC-based control from Beckhoff, on the other hand, was open, flexible, and scalable right from the start – and still is. “Although the models developed with Cordis SUITE can also be transferred to other platforms, our customers stay with Beckhoff because of the unique advantages that PC-based control offers,” states Stefan van Amerongen, Product Lifecycle Architect at Additive Industries.

Based in Eindhoven, Additive Industries uses Cordis SUITE to create the software for its MetalFAB industrial 3D metal printers. The company uses Beckhoff’s powerful hardware and software as its automation platform, a CX5230 Embedded PC as the control platform, AX5000 servo drives to control the AM8000 servomotors, and a large number of EtherCAT and TwinSAFE Terminals. “We chose Beckhoff as our system supplier because of the reliability

and flexibility of the components. The comprehensive Beckhoff portfolio covers a broad spectrum and fits the modular architecture of our machine concept,” says Stefan van Amerongen.

#### Compact and precise drive technology

According to Additive Industries, the MetalFAB range offers the most advanced 3D printers for metals and achieves the highest productivity in its category due to its high degree of automation. “The drive technology and motion control from Beckhoff play an indispensable part in this, with reliability and durability that keep the printers’ productivity high,” says

Stefan van Amerongen. In order to achieve excellent standards of surface quality in 3D printing, drive technology that is both precise and dynamic is required to move the buildplates during the printing process. AM8000 servomotors are also responsible for dispensing the metal powder, a process that is crucial for forming precise contours. In addition, the servomotors are used in automatic handling of the

buildplates by robots. On average, fourteen servomotors are installed in each 3D printer.

The codebase of the 3D printer consists of around one million lines of code, of which Cordis SUITE generates more than half. This PLC code is maintained with just two to three people, whereas the remaining PC code requires a team of



3D printing requires precise motion sequences, which Additive Industries realizes with AX5000 servo drives and AM8000 servomotors.

ten. „This shows how powerful the modeling is, not only reducing the required workforce, but also improving the quality and adaptability of the code”, emphasizes Stefan van Amerongen. At the same time, the quality and adaptability of the control program increases. This is because the behavior and architecture of the machine are described in the models, so the engineers have very quick access to the program modules they want to adapt. Process specialists can model and configure the machine functions without in-depth programming knowledge. “All they have to do is learn to interpret state models,” explains Stefan van Amerongen. Process experts can use a dashboard to customize all of the software’s functions and variables.

#### Low-code engineering embedded in TwinCAT

The single-button deployment concept in Cordis SUITE supports simple rollout of the software and seamless integration of the application into TwinCAT. The TwinCAT runtime combines the PLC, HMI, motion control, and image processing. “This does away with the need for additional systems,” explains Stijn de Bruin, Sales Engineer at Beckhoff Netherlands. In addition, Additive Industries benefits from the advantages of open standard PC technology with operating systems such as Windows or Linux® and familiar interfaces with the machine and information systems.

Jan Peter Meeuwse explains: “Our low-code development layer is supplemented by a generic server application that acts as a bridge between IT and OT systems, facilitating the integration of TwinCAT applications with end users’ IT systems and simplifying comprehensive data logging, for example.”

Easy data integration into IT systems is important for Additive Industries, as most customers want to monitor the 3D printers. “The aerospace and automo-



The axes of a 3D printer – which can number up to fourteen – are driven precisely and dynamically by AM8000 servomotors.

tive industries, for example, need this data for the certification and traceability of their products,” says Stijn de Bruin. Traditional tools can extract sensor data from the process and generate diagrams. Cordis SUITE goes one step further in this case and also displays the historical states of all components or creates comprehensive logs that show the runtime behavior of the software. “This gives a deeper insight into the internal workings of the software and turns the system into an intelligent sensor that provides a wealth of additional machine data,” says Jan Peter Meeuwse.

#### Close cooperation in the next generation

Additive Industries is currently working on the next generation of its MetalFAB machine. This generation required comprehensive extensions to the control program, as part of which it was possible to reuse many of the existing models and, at the same time, build upon the TwinCAT runtime program code. Stefan van Amerongen comments: “What we have really come to appreciate is the EtherCAT diagnostics and the integrated safety-related communication, as well as the fast, expert support from the staff at Beckhoff Netherlands.”

Stefan van Amerongen, Product Lifecycle Architect at Additive Industries

“The comprehensive Beckhoff portfolio covers a broad spectrum and fits the modular architecture of our machine concept,”

More information:

[www.additiveindustries.com](http://www.additiveindustries.com)

[www.cordis-suite.com](http://www.cordis-suite.com)

[www.beckhoff.com/machine-tools](http://www.beckhoff.com/machine-tools)

PC-based control for scaling the production of tracking labels

# Smart labels, smart manufacturing



The C6930 control cabinet Industrial PC with TwinCAT software forms the powerful control core of the production system.

**SATO**  
TECHNICAL SUPPORT 01255 252828  
SERVICE DESK 01255 252799  
Mon - Thu 08:30 to 17:00 Fri - 08:30 to 16:00  
www.satouk.com

Approximately 1.7 million packages are lost or stolen every day across the global goods shipping industry. Traditional tracking methods rely on barcodes or QR codes, scanned at specific points, but they offer little visibility between stops. Reelables, a British start-up, enables real-time logistics tracking from warehouse to doorstep with its Bluetooth and 5G smart labels. To meet growing demand, Reelables needed to increase its speed of production. That's where PC- and EtherCAT-based Beckhoff control technology came in.

Reelables founder Brian Krejcarek had the idea for the company at an unusual moment: he was climbing a hill when he realized that he'd forgotten his ChapStick. This thought evolved into a larger vision: what if there was a way to actively track objects and know what you're missing before you leave the house? Originally imagined as a business-to-consumer (B2C) concept, Reelables pivoted to a business-to-business (B2B) model, recognizing a bigger opportunity in sectors such as freight forwarding, logistics, and warehousing.

The company's goal was to create a tracking label that was so low-cost and scalable, it could be attached to almost anything,



Reelables tracking labels are supplied on reels and can be integrated directly into automated label application processes.



eventually replacing traditional barcodes or QR codes with active trackers that constantly broadcast their location. Today, Reelables produces two types of smart labels:

- Bluetooth tracking labels designed for asset tracking across a wide range of industries, ideal for high-value logistics where delay costs are significant
- temperature-sensitive labels that are accurate to 0.5°C and are used in cold chain applications such as seafood transportation

According to Reelables, both logistics companies and end customers benefit from this real-time tracking. The labels, which are similar in shape and size to a credit card, are supplied on reels that can be directly integrated into automated label application processes, replacing traditional paper or plastic labels entirely.

#### Collaboration with the automation specialist

Oliver Boswall-Perks joined Reelables in 2019 and, in his role as a mechatronics engineer, was tasked with expanding the company's manufacturing capabilities: "Reelables is the only company producing labels that have an integrated printed battery. There are several advantages to this. First, our smart labels are categorized as packaging, meaning that they don't need to be declared at customs. Second, the labels can pass through standard waste streams, aligning with the sustainability goals of our customers."

Having worked with Beckhoff in a previous role, Oliver Boswall-Perks reached out to Bradley McEwan, business development manager at Beckhoff UK. "Reelables approached us with a great proof of concept – a smart Bluetooth label that was gaining popularity in the industry – but their early production set-up wasn't built for scale," explains McEwan. "They needed to shift from

a manual process using non-industrial hardware to a fully automated, high-speed manufacturing line."

Before working with Beckhoff, the Reelables team was producing thousands of labels in a ten-hour shift. As demand grew, the team built up the system, layer by layer, always aiming to increase speed and throughput and improve quality. "It was a classic chicken-and-egg scenario," adds Bradley McEwan. "You need a product to go to market, but you can't invest heavily in production infrastructure until there's demand. As the company's labels started selling well, it became clear that they needed a fully automated system that could grow with them."

The collaboration started with a face-to-face meeting at Reelables' site in London. Beckhoff looked at the company's existing set-up, and spoke to Oliver Boswall-Perks and the team about what they were hoping to achieve. From this, Beckhoff engineered a new system from a series of discrete manufacturing modules into which Beckhoff's TwinCAT automation software could be integrated.

#### The technical implementation

The new production system is based on the Beckhoff automation platform, which is fully integrated with TwinCAT and EtherCAT. In addition to TwinCAT software, the system features industrial PCs, drive technology, EtherCAT Terminals, real-time vision systems, and multi-touch control panels as HMIs. Reelables also benefited from being an early adopter of TwinCAT Vision and Motion integration. Their system runs on Beckhoff's SPT Application Framework – the first implementation of its kind in the United Kingdom. The architecture supports easy expansion and integration of future machines, making it extremely scalable. The framework provides a structured, modular approach to machine sequencing and is fully PackML-compliant. "What really



Project experts Beckhoff product engineer Chris Knight and mechatronics engineer Oliver Boswall-Perks (from left to right)



The 2-channel AX5206 servo drive ensures precise and dynamic movements.

made the difference was that Beckhoff wasn't just selling us hardware," adds Oliver Boswall-Perks. "The experts helped create the whole system – vision, motion, logic – all working together. That level of support is rare, especially for a company of our size."

Reelables also engaged Beckhoff's engineering services. Beckhoff product engineer Chris Knight led the programming effort, working on-site with the Reelables team to develop the machine code, logic, and sequence control over several months. "With a small team of just ten people, Chris Knight's insight was invaluable," adds Oliver Boswall-Perks. He brought extensive expertise that accelerated our progress and helped the team quickly get to grips with the system. He played a key role in mentoring us and connecting us with Beckhoff's wider network of motion and vision experts, which massively sped up the process."

#### Performance boost through optical quality control

The TwinCAT Vision system plays a critical role in quality control. It captures high-resolution images of each label as it moves through the line, calculating precise rotational and positional offsets, checking for defects, and ensuring that glue is dispensed with micron-level accuracy. Importantly, the system also flags and skips labels that would fail further downstream.

The system now captures images of multiple labels simultaneously, enabling faster processing and greater consistency. This allows Reelables to maintain quality at high speed, now producing tens of thousands of labels per shift – a 150% increase compared with the previous system. "Switching to TwinCAT meant that we could integrate real-time vision into the process, something that we relied on humans for before," says Oliver Boswall-Perks. "Now, not only is production faster, but the quality hasn't dropped at all. In fact, it's more consistent."

#### Looking ahead

Reelables is building a full digital record of every label, with data captured at multiple checkpoints throughout the production line. This feeds into an AI-driven analytics system designed to predict failure risk based on adhesive dispensing quality, chip placement, substrate condition, environmental fac-

tors, and more. The system can take real-time corrective actions – such as skipping chip placement or epoxy application – to conserve resources and improve yield and production time.

A next-generation vision system is also underway, with multiple cameras deployed across key inspection stations, all managed by a single Beckhoff Industrial PC. This infrastructure supports machine learning models that will soon classify failures as manufacturing- or field-related, closing the loop between production and real-world performance.

To meet growing demand for labels, Reelables is scaling up production with two new compact lines and a high-throughput system – the Stratus R22M – designed to produce tens of thousands of labels per hour. Three of the four core machines for the Stratus R22M are already built or fully engineered, positioning Reelables to dramatically increase capacity and reduce lead times. "Working with Beckhoff has been a game-changer for us," concludes Oliver Boswall-Perks. "We are now prepared for our next phase of growth, and everything that comes beyond that."



The new Reelables label production system is extremely compact and can be conveniently operated via the Beckhoff multi-touch control panel.

More information:

[www.reelables.com](http://www.reelables.com)

[www.beckhoff.com/vision](http://www.beckhoff.com/vision)

[www.beckhoff.com/intralogistics](http://www.beckhoff.com/intralogistics)

# Semiconductor Technical Working Group: strong momentum, new profiles, and a look ahead



The TWG Semi (seen here at its 25th anniversary meeting) led by ETG Tech Team Lead Florian Essler is one of the most active working groups within the ETG.

Right from the start, the energy was palpable: the discussions went far beyond the fundamentals of EtherCAT, diving deep into implementation details and specific challenges in semiconductor applications. Of special note was the keen interest in advanced EtherCAT features, such as synchronization, which drew significant attention during the Q&A session.

## Profiles in development – and on the move

In the Task Groups working on new device profiles – specifically RFC (Remote Field Controller), OES (Optical Equipment System), and

SCR (Scrubber) – concentrated efforts and genuine cross-vendor collaboration are driving progress toward imminent releases. The goal is clear: the semiconductor industry needs stable, high-performance, and future-proof profiles. The first new industry-relevant standards are expected as early as next year.

Meanwhile, existing profiles are also in motion: After a good ten years of intensive use, several groups are considering the idea of reissuing selected profiles, including the integration of new EtherCAT features and the use of more powerful hardware platforms. This is a clear

sign that the community is ready to take the next steps together.

## Generational shift and knowledge transfer

The group is also undergoing a generational change: Some of the experienced engineers who had been part of TWG Semi since its early days in 2011 have retired. At the same time, new members are stepping in, bringing fresh perspectives, deep technical curiosity, and a strong willingness to learn. This ongoing exchange and transfer of expertise is not only impressive but also ensures the sustainable development of the device profiles and their relevance to the industry.

The collaborative spirit – characterized by openness, technical depth, and mutual respect – makes TWG Semi a prime example of successful industry cooperation. Here, working on open standards is not just a statement, it's an active and ongoing practice.



One of the first events held at the new EUCHNER office location: the Safety over EtherCAT Plug Fest from the EtherCAT Technology Group.

# Safety over EtherCAT Plug Fest in Leinfelden-Echterdingen

Recently, the EtherCAT Technology Group (ETG) once again invited its members to a Plug Fest, this time specifically targeting developers and manufacturers of devices with Safety over EtherCAT (FSoE) functionality. The host of this safety-centric Plug Fest was ETG member company EUCHNER GmbH + Co. KG, which held the event at its new facility in Leinfelden-Echterdingen, Germany, marking the first event of its kind at the new location.

Both the organization and the atmosphere of the event were praised as highly successful by the attendees. A total of 15 companies participated in the interoperability meeting. Tests were conducted on 11 different FSoE Sub-Instances and 5 FSoE MainInstances. Nearly all conceivable combinations could be tested during the event, almost all of them with successful results. In the few cases where issues arose, potential solutions were proposed, and valuable insights for improving interoperability were gained. This is precisely the key benefit of ETG's Plug Fests: early technical feedback and troubleshooting through direct, in-person exchange with other developers and ETG experts.

One participant summarized the event as follows: "I thoroughly enjoyed participating in the Safety over EtherCAT Plug Fest. This was not only because of the opportunity to test with FSoE MainInstance devices used by some of my customers, which are not available in my own test environment, but also because of the chance to meet with other participants, ETG experts, and the 'mastermind' behind the FSoE CTT in person. In a pleasant and relaxed atmosphere, we were able to conduct tests

together and exchange ideas about our Safety over EtherCAT implementations."

Dr. Guido Beckmann, Chair of the Safety Working Group at ETG, added: "The strong response to our specialized Safety over EtherCAT Plug Fests clearly demonstrates how important interoperability and exchange are for our members in this technology area. The wide range of devices tested and the active participation of developers underscore the market acceptance and adoption of Safety over EtherCAT."

Further Safety over EtherCAT Plug Fests are planned by the EtherCAT Technology Group in the near future. Dates will be published on the ETG website when finalized.

# EtherCAT worldwide: successful roadshow in Brazil

The EtherCAT Technology Group (ETG) is once again on a global tour. With its popular seminar series, the organization brings the latest know-how, practical insights, and opportunities for direct exchange to key industrial regions around the world. Most recently, the event series made a stop in Brazil.



A special location for the seminar break in Caxias do Sul

The Brazilian community once again proved itself to be especially committed, open, and enthusiastic about technology. In addition to presentations by ETG and sponsor Beckhoff, the well-attended events featured in-depth discussions on the latest developments in the

EtherCAT ecosystem, practical Q&A sessions, and active networking. The strong positive feedback shows that Brazil is not only an important growth market, but also a place where the collaborative spirit of ETG is especially vibrant.



All four EtherCAT seminars in Brazil were well attended.

The ETG seminars are a cornerstone of the organization's global activities. They strengthen direct connections with users, developers, and decision-makers on-site, while promoting international knowledge exchange around EtherCAT.



## More about Beckhoff



Company



Global presence



Events & dates



Jobs



Products



Industries



Support